

**Product Specification**

---

# NHD-7.0-800480AF-LSXP-T

## IPS TFT Liquid Crystal Display

<b>NHD-</b>	Newhaven Display
<b>7.0-</b>	7.0" Diagonal
<b>800480-</b>	800x480 Pixels
<b>AF-</b>	Model
<b>L-</b>	LVDS Interface
<b>S-</b>	High Brightness, White LED Backlight
<b>X-</b>	TFT
<b>P-</b>	IPS, Wide Temperature
<b>T-</b>	4-Wire Resistive Touch Panel

## Table of Contents

Document Revision History.....	2
Mechanical Drawing.....	3
Pin Description.....	4
Electrical Characteristics.....	5
Optical Characteristics.....	5
Touch Panel Characteristics.....	6
Driver Information.....	6
Timing Characteristics.....	7
Quality Information.....	9

---

## Additional Resources

- **Support Forum:** <https://support.newhavendisplay.com/hc/en-us/community/topics>
- **GitHub:** <https://github.com/newhavendisplay>
- **Example Code:** <https://support.newhavendisplay.com/hc/en-us/categories/4409527834135-Example-Code/>
- **Knowledge Center:** [https://www.newhavendisplay.com/knowledge\\_center.html](https://www.newhavendisplay.com/knowledge_center.html)
- **Quality Center:** [https://www.newhavendisplay.com/quality\\_center.html](https://www.newhavendisplay.com/quality_center.html)
- **Precautions for using LCDs/LCMs:** <https://www.newhavendisplay.com/specs/precautions.pdf>
- **Warranty / Terms & Conditions:** <https://www.newhavendisplay.com/terms.html>



## Document Revision History

Revision	Date	Description	Changed By
-	10/09/2024	Initial Release	KL

# Mechanical Drawing

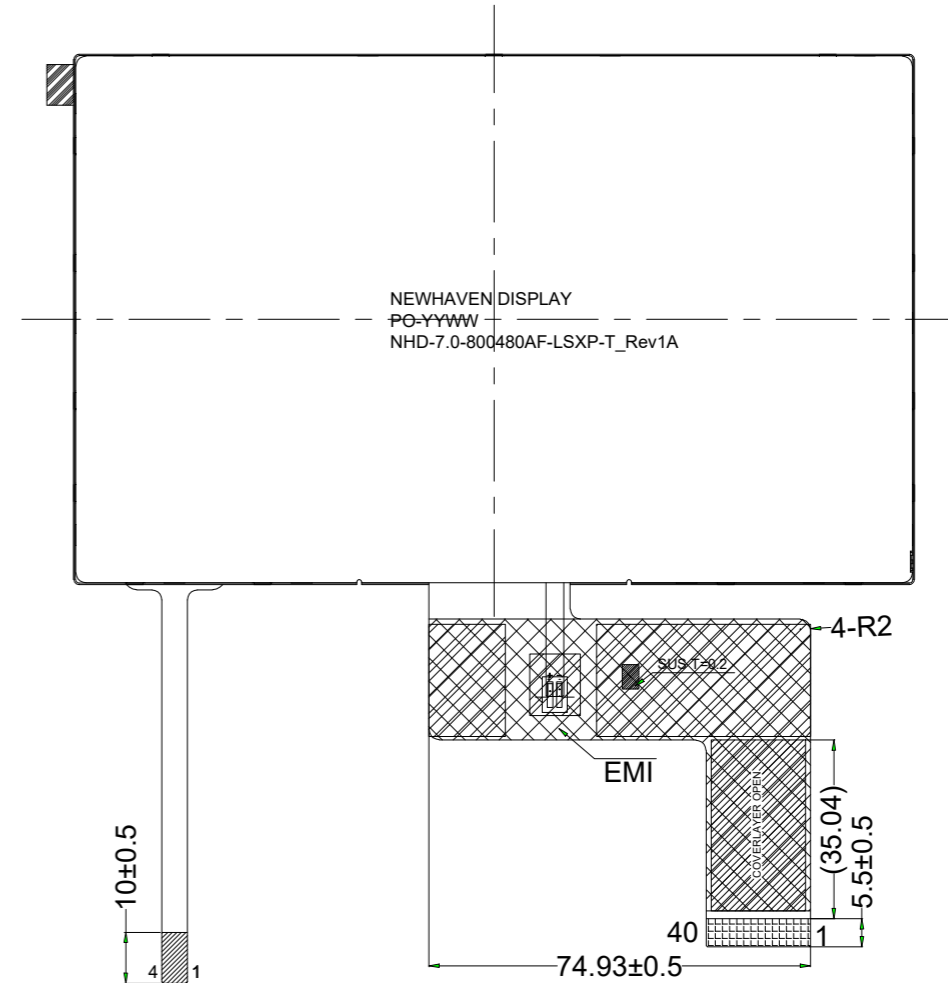
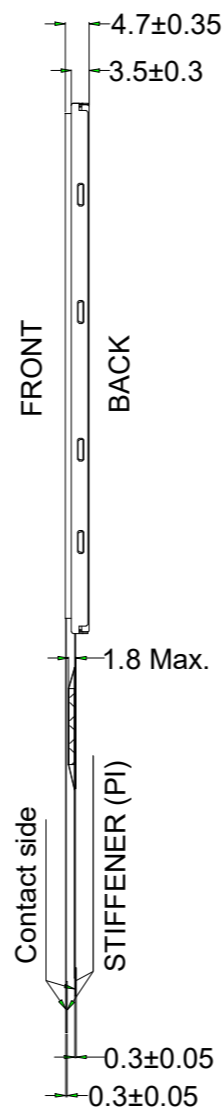
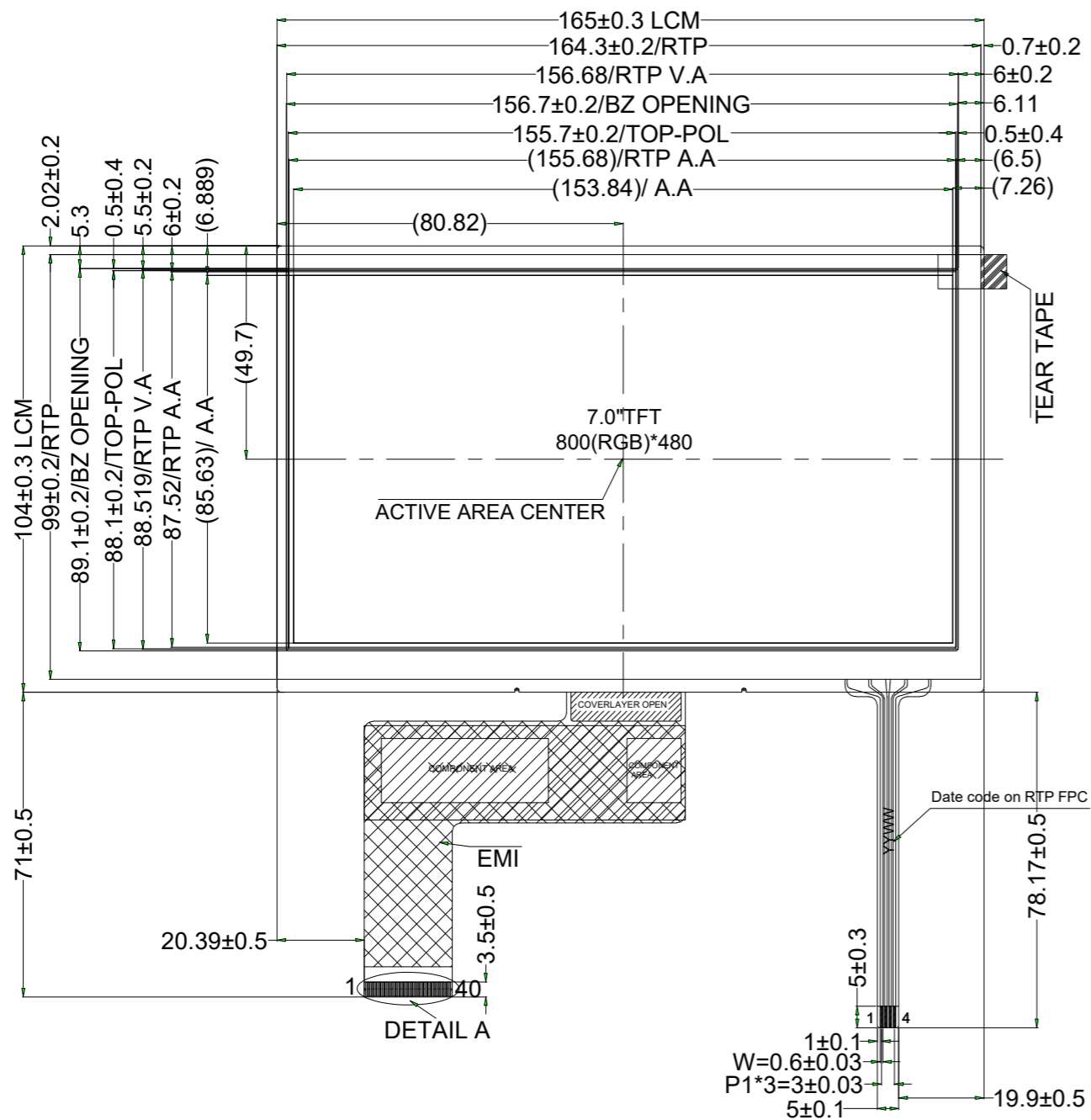

## TFT

PIN	SYMBOL
1	NC
2	VDD
3	VDD
4	NC
5	GRB
6	DISP
7	GND
8	RX0N
9	RX0P
10	GND
11	RX1N
12	RX1P
13	GND
14	RX2N
15	RX2P
16	GND
17	DCLKN
18	DCLKP
19	GND
20	RX3N
21	RX3P
22	GND
23	NC
24	NC
25	GND
26	NC
27	BIST_EN
28	LVDS_SEL
29	NC
30	GND
31	NC
32	NC
33	HDIR
34	VDIR
35	NC
36	LED-K
37	LED-K
38	NC
39	LED-A
40	LED-A

## RTP

1.	XL
2.	YD
3.	XR
4.	YU

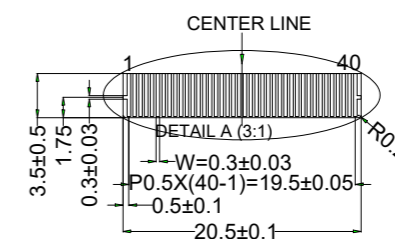

- Product Description: 7.0" 800x480 IPS TFT w/ Resistive Touch**
1. Driver IC: ST7277
  2. Interface: LVDS TFT, 4-wire RTP
  3. Power Requirement: 3.3V TFT, 9.3V/180mA Backlight
  4. Optical Features: Normally Black, Transmissive, Anti-Glare, 780cd/m<sup>2</sup>
  5. Recommended FFC Connector:
    - TFT: 40pin 0.5mm pitch; Ex. Molex 54104-4031
    - RTP: 4pin 1.0mm pitch; Ex. Molex 52207-0485
  6. EMI Shielded FPC

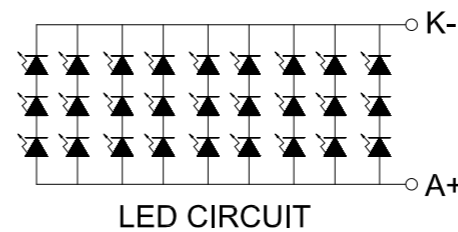

<b>Standard Tolerance:</b> (Unless otherwise specified)  Linear: ±0.3mm		
	Drawing/Part Number: <b>NHD-7.0-800480AF-LSXP-T</b>	Revision: <b>1A</b>
<b>Unless otherwise specified:</b> • Dimensions are in Millimeters • Third Angle Projection	Drawn By: K. Lewis Drawn Date: 10/09/2024	Approved By: K. Lewis Approved Date: 10/09/2024
This drawing is solely the property of Newhaven Display International, Inc. The information it contains is not to be disclosed, reproduced or copied in whole or part without written approval from Newhaven Display.		

## Pin Description

Pin No.	Symbol	Connection	Function Description
1	NC	-	No connection
2-3	V <sub>DD</sub>	Power Supply	Supply voltage for LCD (+3.3V)
4	NC	-	No connection
5	GRB	MPU	Active LOW Reset signal (normally pull high)
6	DISP	MPU	Active LOW Standby signal (normally pull high)
7	GND	Power Supply	Power Ground
8	RX1N	MPU	-LVDS differential data input CH0
9	RX0P	MPU	+LVDS differential data input CH0
10	GND	Power Supply	Ground
11	RX1N	MPU	-LVDS differential data input CH1
12	RX1P	MPU	+LVDS differential data input CH1
13	GND	Power Supply	Ground
14	RX2N	MPU	-LVDS differential data input CH2
15	RX2P	MPU	+LVDS differential data input CH2
16	GND	Power Supply	Ground
17	DCLKN	MPU	-LVDS differential Clock
18	DCLKP	MPU	+LVDS differential Clock
19	GND	Power Supply	Ground
20	RX3N	MPU	-LVDS differential data input CH3
21	RX3P	MPU	+LVDS differential data input CH3
22	GND	Power Supply	Ground
23 - 24	NC	-	No connection
25	GND	Power Supply	Ground
26	NC	-	No connection
27	BIST_EN	MPU	Built in Self-Test BIST = H: Self-Test Enabled BIST = L: Normal Operation (Default)
28	LVDS_SEL	MPU	Data Input Format: LVDS = L: 3 Lane (6-bit) Input LVDS = H: 4 Lane (8-bit) Input (Default)
29	NC	-	No connection
30	GND	Power Supply	Power Ground
31-32	NC	-	No connection
33	HDIR	MPU	Horizontal Scan Direction: HDIR = H: Normal Scan (Default) HDIR = L: Reverse Scan
34	VDIR	MPU	Vertical Scan Direction: VDIR = H: Normal Scan (Default) VDIR = L: Reverse Scan
35	NC	-	No connection
36-37	LED-K	Power Supply	Backlight Cathode (Ground)
38	NC	-	No connection
39-40	LED-A	Power Supply	Backlight Anode (180mA @ 9.3V)

**Recommended LCD connector:** 40pin 0.5mm pitch FFC. Molex p/n: 54104-4031 (top contact)

### Resistive Touch Panel:

Pin No.	Symbol	External Connection	Function Description
1	XL	Touch Controller	Left
2	YD	Touch Controller	Down
3	XR	Touch Controller	Right
4	YU	Touch Controller	Up

**Recommended LCD connector:** 1.0mm pitch 4-Conductor FFC. Molex p/n: 52207-0485



## Electrical Characteristics

Item	Symbol	Condition	Min.	Typ.	Max.	Unit
Operating Temperature Range	T <sub>OP</sub>	Absolute Max	-20	-	+70	°C
Storage Temperature Range	T <sub>ST</sub>	Absolute Max	-30	-	+80	°C
Supply Voltage for LCD	V <sub>DD</sub>	-	3.1	3.3	3.6	V
Supply Current for LCD	I <sub>DD</sub>	V <sub>DD</sub> = 3.3V	45	90	135	mA
LVDS Differential input high Threshold voltage	R <sub>XVTH</sub>	R <sub>XVCM</sub> = 1.2V	-	-	100	mV
LVDS Differential input low Threshold voltage	R <sub>XVTL</sub>		-100	-	-	mV
LVDS Differential input common mode voltage	R <sub>XVCM</sub>	-	VID /2	-	2.4· VID /2	V
LVDS Differential voltage	VID	-	200	-	600	mV
Backlight Supply Current	I <sub>LED</sub>	-	-	180	-	mA
Backlight Supply Voltage	V <sub>LED</sub>	I <sub>LED</sub> = 180 mA	8.3	9.3	10.2	V
Backlight Lifetime*	-	T <sub>OP</sub> = 25° C	30,000	-	-	Hrs.

\*Backlight lifetime is rated as Hours until **half-brightness**, under normal operating conditions. The LED of the backlight is driven by current drain; drive voltage is for reference only. Drive voltage must be selected to ensure backlight current drain is below MAX level stated

## Optical Characteristics

Item	Symbol	Condition	Min.	Typ.	Max.	Unit	
Optimal Viewing Angles	Top	φY+	-	85	-	°	
	Bottom	φY-	-	85	-	°	
	Left	θX-	-	85	-	°	
	Right	θX+	-	85	-	°	
Contrast Ratio	CR	-	800	1000	-	-	
Luminance	L <sub>V</sub>	I <sub>LED</sub> = 180 mA	624	780	-	cd/m <sup>2</sup>	
Response Time (Rise + Fall)	T <sub>R</sub> + T <sub>F</sub>	T <sub>OP</sub> = 25°C	-	25	-	ms	
Chromaticity	Red	X <sub>R</sub>	-	0.557	0.607	0.657	-
		Y <sub>R</sub>	-	0.301	0.351	0.401	-
	Green	X <sub>G</sub>	-	0.276	0.326	0.376	-
		Y <sub>G</sub>	-	0.546	0.596	0.646	-
	Blue	X <sub>B</sub>	-	0.077	0.127	0.177	-
		Y <sub>B</sub>	-	0.093	0.143	0.193	-
	White	X <sub>W</sub>	-	0.245	0.295	0.345	-
		Y <sub>W</sub>	-	0.304	0.354	0.375	-

## Touch Panel Characteristics

Item	Min.	Typ.	Max.	Unit
Linearity	-3	-	3	%
Circuit Resistance – X-Axis	50	-	450	$\Omega$
Circuit Resistance – Y-Axis	350	-	1100	$\Omega$
Insulation Resistance	20	-	-	M $\Omega$
Operating Voltage	-	-	5	V
Chattering	-	-	15	ms
Activation Force	30	-	100	g
Pen Writing Durability	100,000	-	-	Characters
Pitting Durability	1,000,000	-	-	Touches
Surface Hardness	3	-	-	H

## Driver Information

Built-in ST7277 Source Driver: <https://support.newhavendisplay.com/hc/en-us/articles/22014397027991-ST7277>

## Timing Characteristics

Parameter	Symbol	Spec			Unit	Condition
		Min.	Typ.	Max.		
Clock frequency	R <sub>XFCLK</sub>	23	25	27	MHz	-
Input data skew margin	T <sub>RSKM</sub>	400	-	-	pS	-
Clock high time	T <sub>LVCH</sub>	-	4/(7 * R <sub>XFCLK</sub> )	-	nS	-
Clock low time	T <sub>LVCL</sub>	-	3/(7 * R <sub>XFCLK</sub> )	-	nS	-
PLL wake-up time	T <sub>emPLL</sub>	-	-	150	μS	-

Parameter	Symbol	Spec			Unit	Condition
		Min.	Typ.	Max.		
Modulation Frequency	SSCMF	-	-	100	KHz	-
Modulation Rate	SSCMR	-	-	±3	%	-

### LVDS input Timing

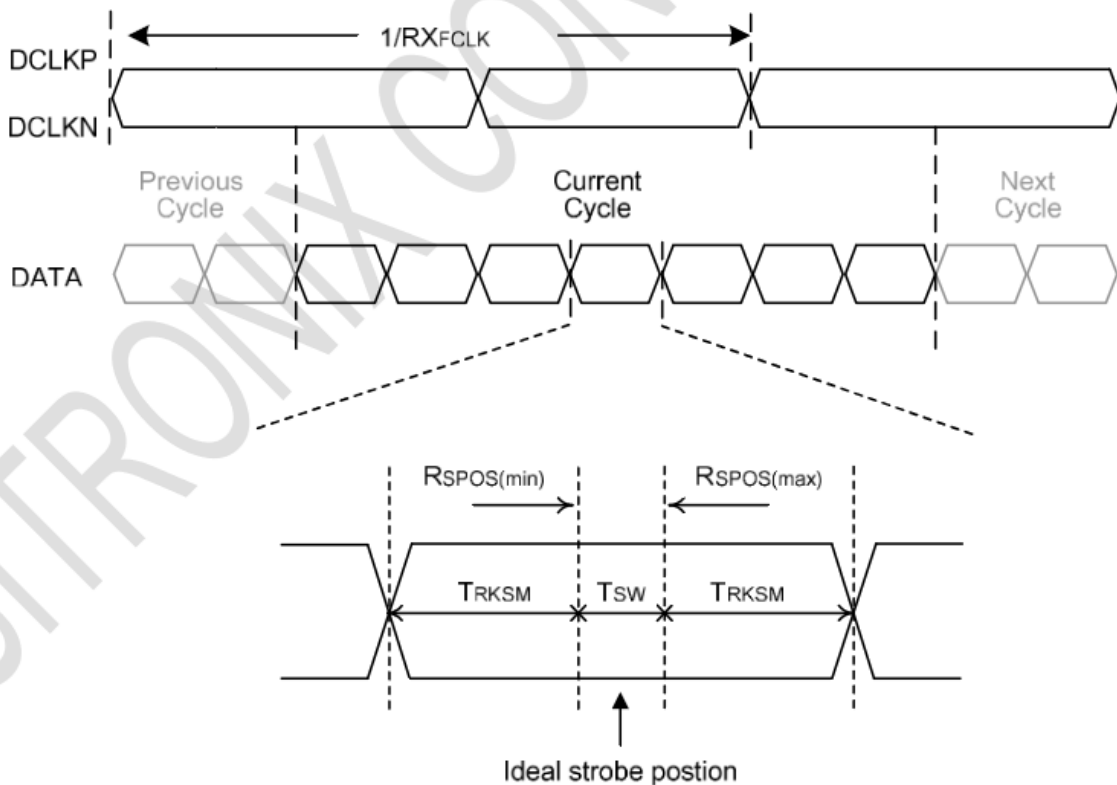

RRKSM : Receiver strobe margin  
 RSPOS : Receiver strobe position  
 T<sub>sw</sub> : Strobe width (internal DATA sampling window)

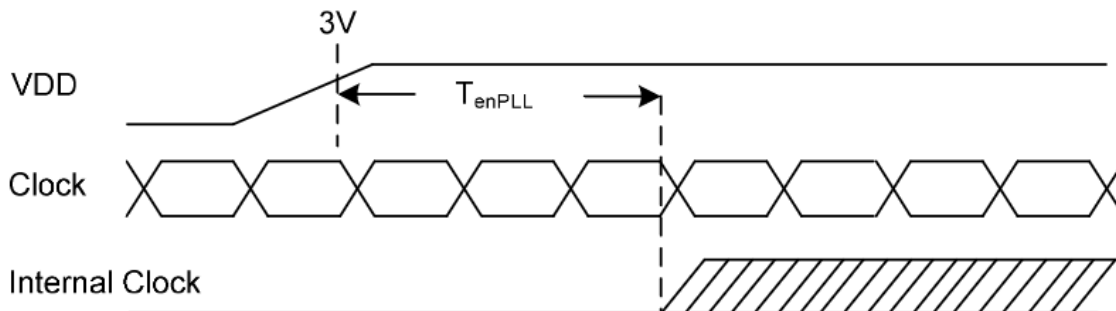



**3 Lane VESA Mode Color Bit Map**

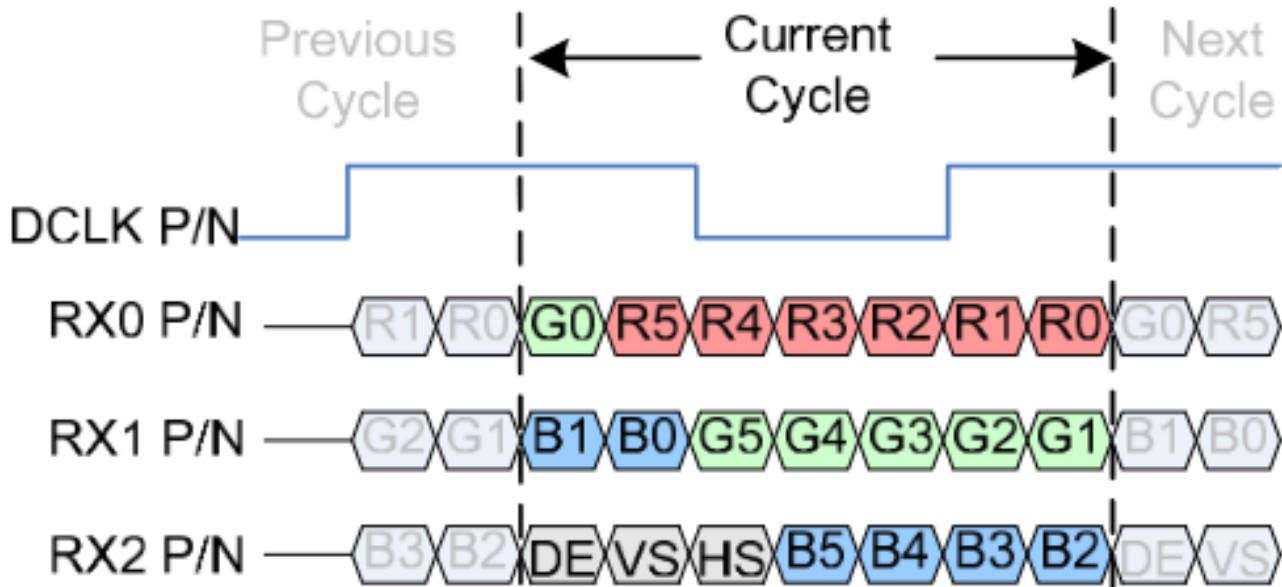

**4 Lane VESA Data Format Color Bit Map**

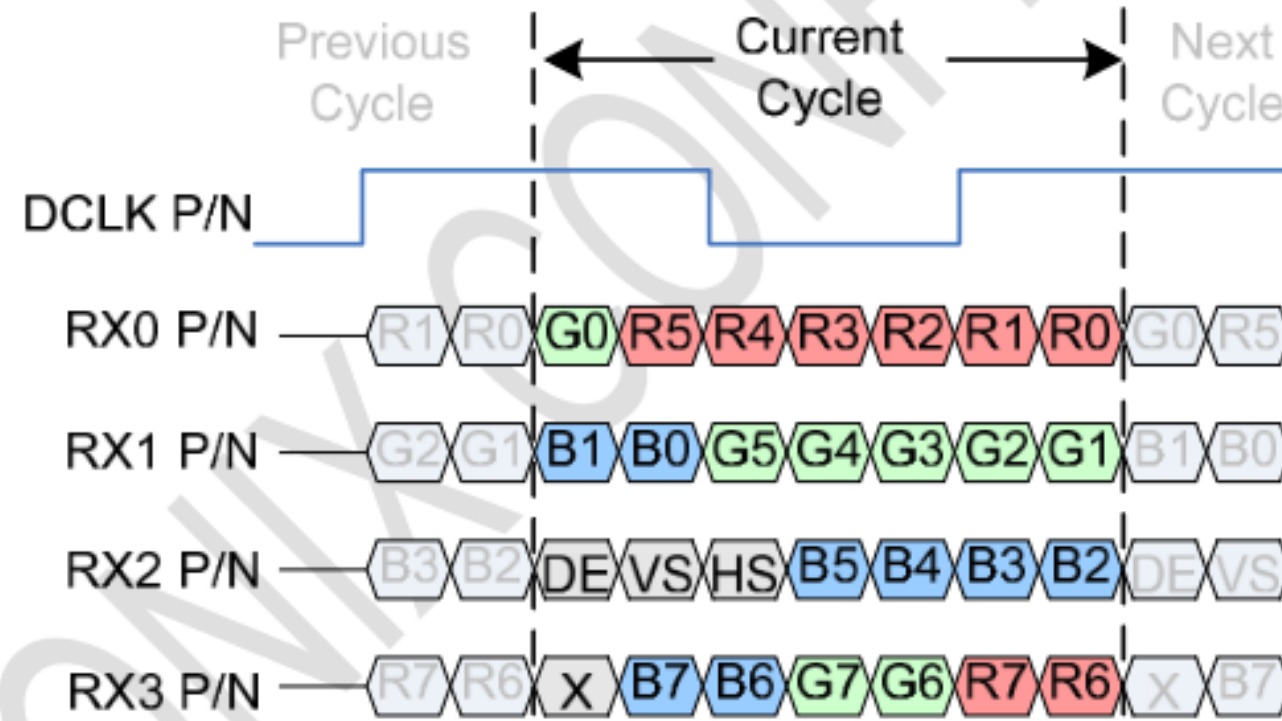

## Quality Information

Test Item	Content of Test	Test Condition	Note
High Temperature storage	Endurance test applying the high storage temperature for a long time.	+80°C , 96hrs	2
Low Temperature storage	Endurance test applying the low storage temperature for a long time.	-30°C , 96hrs	1,2
High Temperature Operation	Endurance test applying the electric stress (voltage & current) and the high thermal stress for a long time.	+70°C 96hrs	2
Low Temperature Operation	Endurance test applying the electric stress (voltage & current) and the low thermal stress for a long time.	-20°C , 96hrs	1,2
High Temperature / Humidity Storage	Endurance test applying the electric stress (voltage & current) and the high thermal with high humidity stress for a long time.	+50°C , 90% RH , 96hrs	1,2
Thermal Shock resistance	Endurance test applying the electric stress (voltage & current) during a cycle of low and high thermal stress.	-20°C,60min -> 70°C,60 min =20 cycles	
Vibration test	Endurance test applying vibration to simulate transportation and use.	Frequency range:10Hz~50Hz Acceleration of gravity:5G X, Y, Z 30 min for each direction	3
Static electricity test	Endurance test applying electric static discharge.	Air: ±8kV 150pF/330 Ω ; Contact: ±4kV 150pF/330 Ω For 5 times each.	

**Note 1:** No condensation to be observed.

**Note 2:** Conducted after 4 hours of storage at 25°C, 0%RH.

**Note 3:** Test performed on product itself, not inside a container.

