

**Product Specification**

---

# NHD-6.8-4801280AF-ASXP-CTP

## TFT Liquid Crystal Display

<b>NHD-</b>	Newhaven Display
<b>6.8-</b>	6.8" Diagonal
<b>480128-</b>	480xRGBx1280 Pixels
<b>AF-</b>	Model
<b>A-</b>	Built-in Driver / No Controller
<b>S-</b>	High Brightness, White LED Backlight
<b>X-</b>	TFT
<b>P-</b>	IPS, Wide Temperature
<b>CTP-</b>	Capacitive Touch Panel

## Table of Contents

Document Revision History.....	2
Mechanical Drawing .....	3
Pin Description .....	4
Polarity and Data Lane Selection.....	5
Internal Registers .....	5
SPI Interface Mode .....	6
MIPI DSI Interface Mode.....	7
Recommended Timing Values .....	7
LVDS Interface Mode .....	8
Electrical Characteristics .....	9
MIPI Characteristics .....	9
LVDS Characteristics .....	10
Optical Characteristics .....	11
Driver/Controller Information .....	11
Capacitive Touch Panel Registers .....	12
Timing Characteristics- TFT Display .....	15
Timing Characteristics – Capacitive Touch Panel.....	21
Quality Information .....	24

## Additional Resources

- **Support Forum:** <https://support.newhavendisplay.com/hc/en-us/community/topics>
- **GitHub:** <https://github.com/newhavendisplay>
- **Example Code:** <https://support.newhavendisplay.com/hc/en-us/categories/4409527834135-Example-Code/>
- **Knowledge Center:** [https://www.newhavendisplay.com/knowledge\\_center.html](https://www.newhavendisplay.com/knowledge_center.html)
- **Quality Center:** [https://www.newhavendisplay.com/quality\\_center.html](https://www.newhavendisplay.com/quality_center.html)
- **Precautions for using LCDs/LCMs:** <https://www.newhavendisplay.com/specs/precautions.pdf>
- **Warranty / Terms & Conditions:** <https://www.newhavendisplay.com/terms.html>



## Document Revision History

Revision	Date	Description	Changed By
-	03/10/2026	Initial Release	KL

# Mechanical Drawing

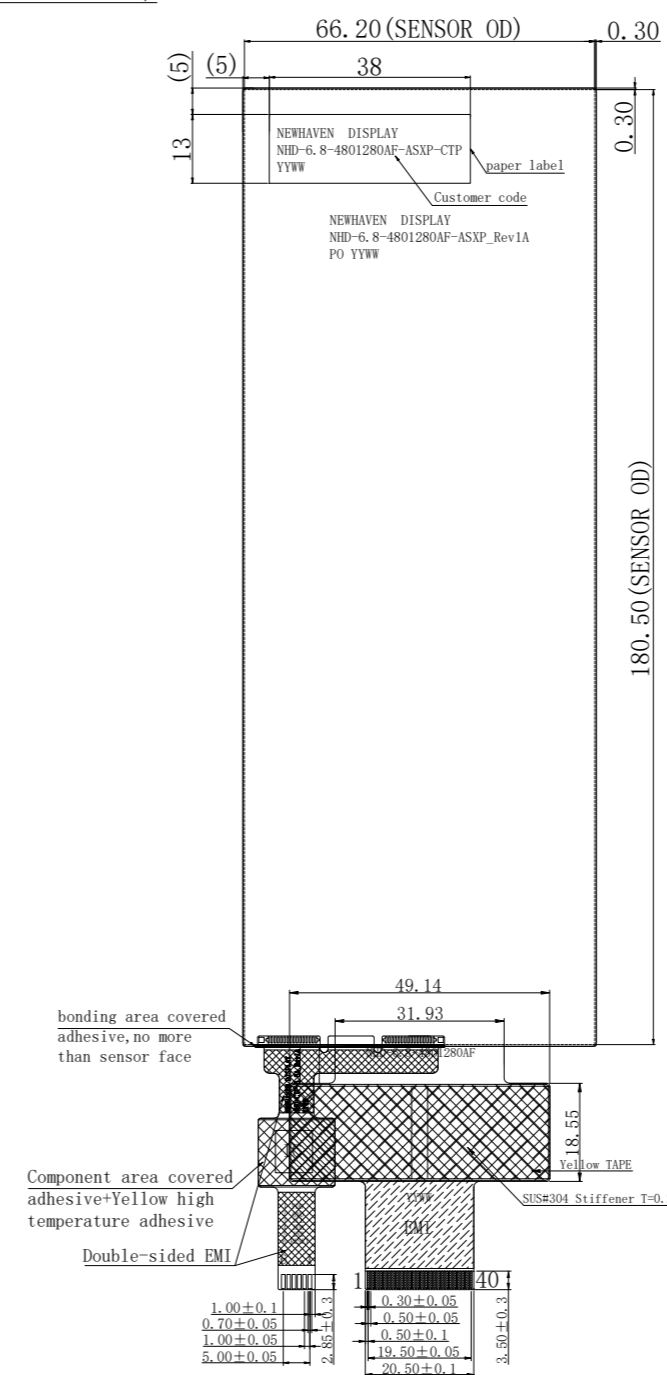
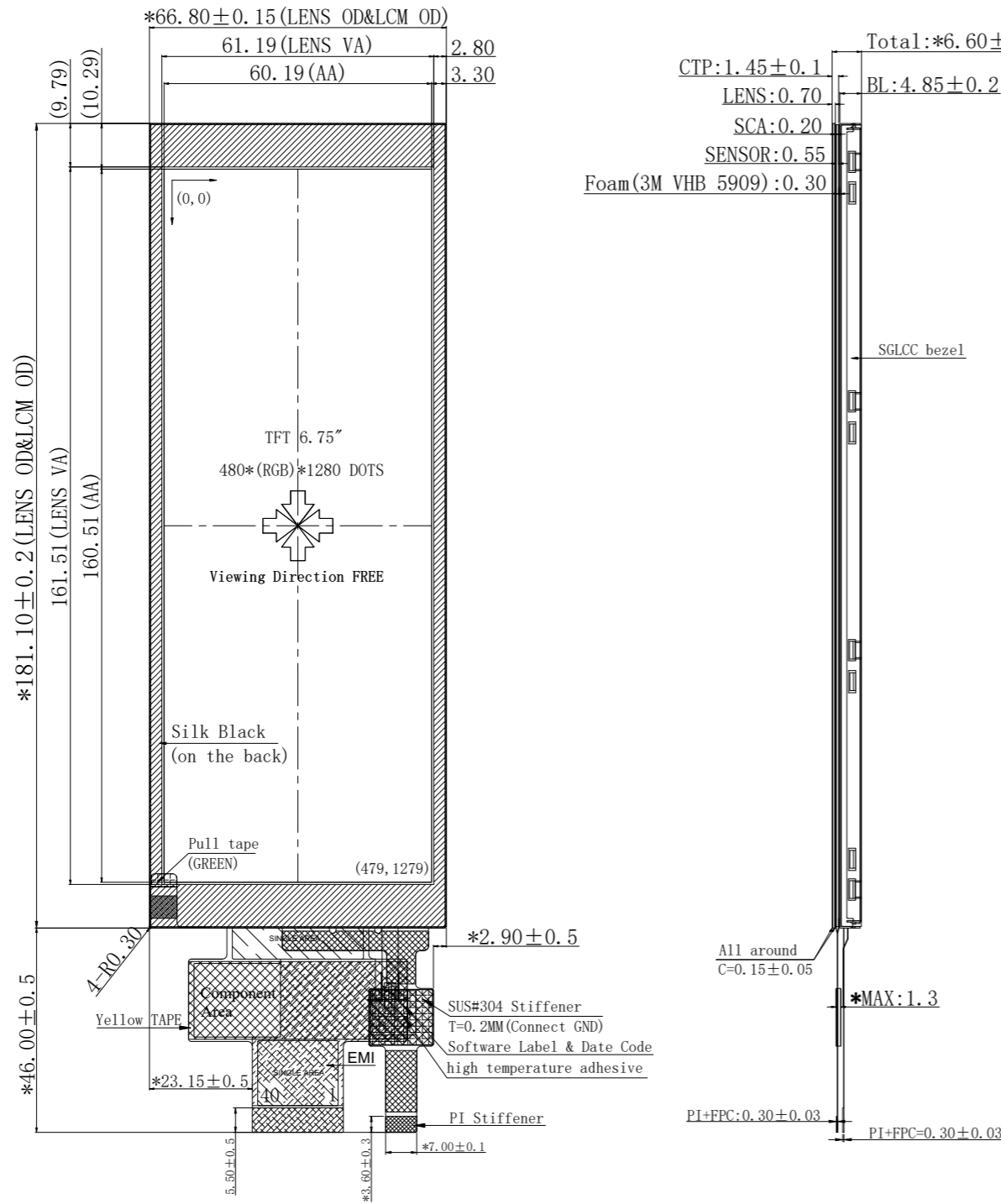

TFT	
PIN	SYMBOL
1	LED_K
2	LED_A
3	NC
4	VCC
5	GND
6	MIPI_D0N
7	MIPI_D0P
8	GND
9	MIPI_D1N
10	MIPI_D1P
11	GND
12	MIPI_CLKN
13	MIPI_CLKP
14	GND
15	SPI_CSX
16	SPI_SCL
17	SPI_SDI
18	SPI_SDO
19	TE
20	RESX
21	IMO
22	BIST_EN
23	GND
24	LVDS_D0P
25	LVDS_D0N
26	GND
27	LVDS_D1P
28	LVDS_D1N
29	GND
30	LVDS_CLKP
31	LVDS_CLKN
32	GND
33	LVDS_D2P
34	LVDS_D2N
35	GND
36	LVDS_D3P
37	LVDS_D3N
38	GND
39	NC
40	VPP_OTP

CTP	
PIN	DEFINE
1	VDD 3.3V
2	GND
3	SCL 3.3V
4	SDA 3.3V
5	INT
6	RESET

Product Description: 6.8" 480x1280 IPS TFT w/ Capacitive Touch

1. Driver IC: NV3051F-L TFT, FT5426G CTP
2. Interface: 2-lane MIPI DSI, LVDS, I<sup>2</sup>C CTP
3. Power Requirement: 3.3V TFT, 18V/170mA Backlight, 3.3V CTP
4. Optical Features: Normally Black, Transmissive, 1020cd/m<sup>2</sup>
5. Recommended FFC Connector:  
TFT: 40pin 0.5mm pitch; Molex 54132-4062  
CTP: 6pin 1.0mm pitch; Molex 52271-0679
6. Key Features: Built-in EMI Shielding, 10-point Multitouch

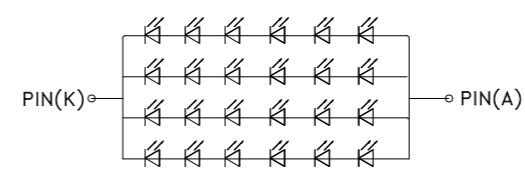

LED CIRCUIT DIAGRAM

<b>Standard Tolerance:</b> (Unless otherwise specified)  Linear: ±0.3mm		
	Drawing/Part Number: <b>NHD-6.8-4801280AF-ASXP-CTP</b>	Revision: -
<b>Unless otherwise specified:</b> • Dimensions are in Millimeters • Third Angle Projection	Drawn By: K. Lewis	Approved By: K. Lewis
	Drawn Date: 03/10/2026	Approved Date: 03/10/2026
This drawing is solely the property of Newhaven Display International, Inc. The information it contains is not to be disclosed, reproduced or copied in whole or part without written approval from Newhaven Display.		

## Pin Description

TFT:

Pin No.	Symbol	External Connection	Function Description
1	LED_K	LED Power Supply	Backlight Cathode (Ground)
2	LED_A	LED Power Supply	Backlight Anode (170mA @ 18V)
3	NC	-	No Connect
4	V <sub>DD</sub>	Power Supply	Power Supply for LCD and Logic (3.3V)
5	GND	Power Supply	Ground
6	MIPI_D0N	MPU	-MIPI DSI Differential Data Negative input Lane 0
7	MIPI_D0P	MPU	+MIPI DSI Differential Data Positive input Lane 0
8	GND	Power Supply	Ground
9	MIPI_D1N	MPU	-MIPI DSI Differential Data Negative input Lane 1
10	MIPI_D1P	MPU	+MIPI DSI Differential Data Positive input Lane 1
11	GND	Power Supply	Ground
12	MIPI_CLKN	MPU	-MIPI DSI Differential Clock Negative input
13	MIPI_CLKP	MPU	+MIPI DSI Differential Clock Positive input
14	GND	Power Supply	Ground
15	SPI_CSX	MPU	Active LOW Chip Select signal
16	SPI_SCL	MPU	Serial Clock signal
17	SPI_SDI	MPU	Serial Data Input
18	SPI_SDO	MPU	Serial Data Output
19	TE	MPU	Tearing Effect Output
20	RESX	MPU	Active LOW Reset signal
21	IMO	MPU	Polarity and Data Lane Swap signal
22	BIST_EN	MPU	Built in Self-Test BIST = H: Self- Test Enabled BIST = L: Normal Operation
23	GND	Power Supply	Ground
24	LVDS_D0P	MPU	+LVDS Differential Data Positive input CH0
25	LVDS_D0N	MPU	-LVDS Differential Data Negative input CH0
26	GND	Power Supply	Ground
27	LVDS_D1P	MPU	+LVDS Differential Data Positive input CH1
28	LVDS_D1N	MPU	-LVDS Differential Data Negative input CH1
29	GND	Power Supply	Ground
30	LVDS_CLKP	MPU	+LVDS differential positive Clock input
31	LVDS_CLKN	MPU	-LVDS differential negative Clock input
32	GND	Power Supply	Ground
33	LVDS_D2P	MPU	+LVDS Differential Data Positive input CH2
34	LVDS_D2N	MPU	-LVDS Differential Data Negative input CH2
35	GND	Power Supply	Ground
36	LVDS_D3P	MPU	+LVDS Differential Data Positive input CH3
37	LVDS_D3N	MPU	-LVDS Differential Data Negative input CH3
38	GND	Power Supply	Ground
39	NC	-	No Connect
40	VPP_OTP	-	<b>Don't Use – Leave as No Connect</b>

**Recommended LCD connector:** 0.5mm pitch 40-Conductor FFC. Molex p/n: 54132-4062 or similar

**NOTE:** When using MIPI, display must be initialized via SPI before sending pixel data. SPI cannot be used for pixel data.



### Capacitive Touch Panel:

Pin No.	Symbol	External Connection	Function Description
1	V <sub>DD</sub>	Power Supply	Supply voltage for Logic (3.3V)
2	V <sub>SS</sub>	Power Supply	Ground
3	SCL	MPU	Serial I2C Clock (Requires 4.7KΩ pull-up resistor)
4	SDA	MPU	Serial I2C Data (Requires 4.7kΩ pull-up resistor)
5	/INT	MPU	Interrupt signal from touch panel module to host
6	/RESET	MPU	Active LOW Reset signal

**Recommended connector:** 6pin, 1.0mm pitch, FFC connector. Molex P/N 52271-0679

## Polarity and Data Lane Selection

IMO	DOP/N	D1P/N	CLKP/N
0	DOP/N	D1P/N	CLKP/N
1	DON/P	D1N/P	CLKN/P

## Internal Registers

The NV3051F-L driver supports high speed serial interface, MIPI to configure the system via accessing command registers. While accessing the command registers, the information that indicates which register would be accessed should be sent first. After that, the new value can be updated via system interface. Updating command instructions can also be accomplished by using all supporting system interfaces.

The NV3051F-L driver has the following major categories of instructions:

- System function instructions (User Command Set).
- Customer Command List and Description (Manufacturer Command Set / Command 2).

Since updating these instructions are asynchronous to the internal clock of the NV3051F-L driver, the updating procedure will require no waiting cycles. Furthermore, the updating procedure will not interfere with the processing of the host controller, this makes instructions can be handled smoothly and efficiently.

The following contents will describe the supported instructions in detail:

- System function commands

After the H/W reset by RESX pin or S/W reset by SWRESET command, each internal register will return to the default state (Please refer to “RESET TABLE” section). The commands 10h, 11h, 20h, 21h, 22h, 23h, 28h, 29h, 36h will be updated only during V-sync periods while module is in the “Sleep Out” mode to avoid abnormal visual effects and will be updated immediately in the “Sleep In” mode. The Read Display Power Mode (0Ah), Read Display MADCTL (0Bh), Read Display Pixel Format (0Ch), Read Display Image Mode (0Dh), Read Display Signal Mode (0Eh), and Read Display Self Diagnostic Result (0Fh) will be updated immediately in both “Sleep In” and “Sleep Out” mode

System function command accessing flow is described as the following example.

Example 1: Sleep Out  
 CMDWR 0x11

Example 2: Display On  
 CMDWR 0x29



Example 3: TE ON  
 CMDWR 0x35  
 DATWR 0x00

## SPI Interface Mode

NV3051F-L driver requires SPI to initialize the display before sending pixel data over MIPI. SPI cannot be used for sending pixel data.

The serial interface is used to communicate between the microcontroller and the LCD driver chip. It contains CSX (chip select), SCL (serial clock), SDI (serial data input) and SDO (serial data output). Serial clock (SCL) is used for interface with MPU only, so it can be stopped when no communication is necessary. If the host places the SDI line into high-impedance state during the read intervals, then the SDI and SDO can be tied together.

### SPI Write Mode

#### Register Write: Singal Parameter

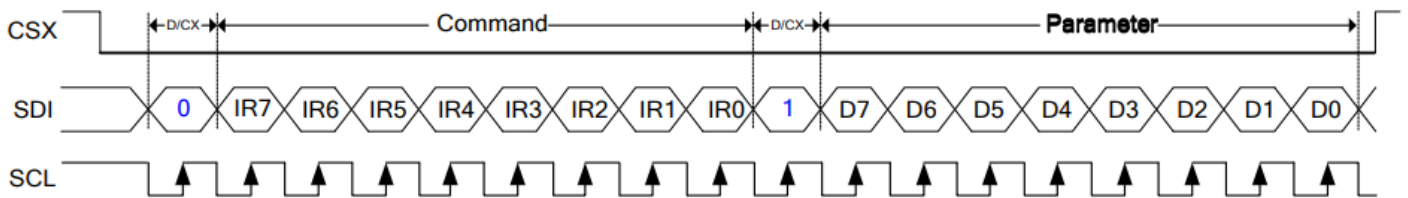

Figure: SPI Protocol for write

### SPI Read Mode

#### Register Read: Without dummy clock

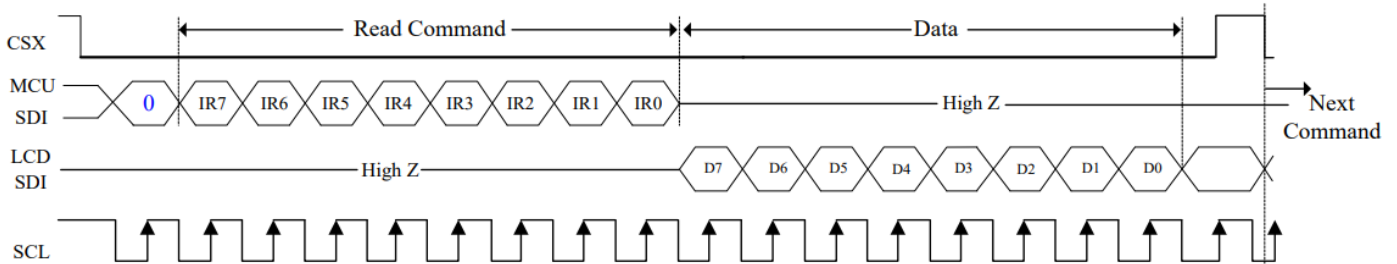

Figure: SPI Protocol for register read mode

## MIPI DSI Interface Mode

In the MIPI video mode, the frame is transmitted from the host processor to a display module as a sequence of pixels, with each horizontal line of the image data sent as a group of consecutive pixels.

Vsync (VS) indicates the beginning of each frame of the displayed image.

Hsync (HS) signals the beginning of each horizontal line of pixels.

Each pixel value (16-, 18-, or 24-bit data) is transferred from the host processor to the display module during one pixel period. The rising edge of PCLK is used by the display module to capture pixel data.

Since PCLK runs continuously, control signal DE is required to indicate when valid pixel data is being transmitted on the pixel data signals.

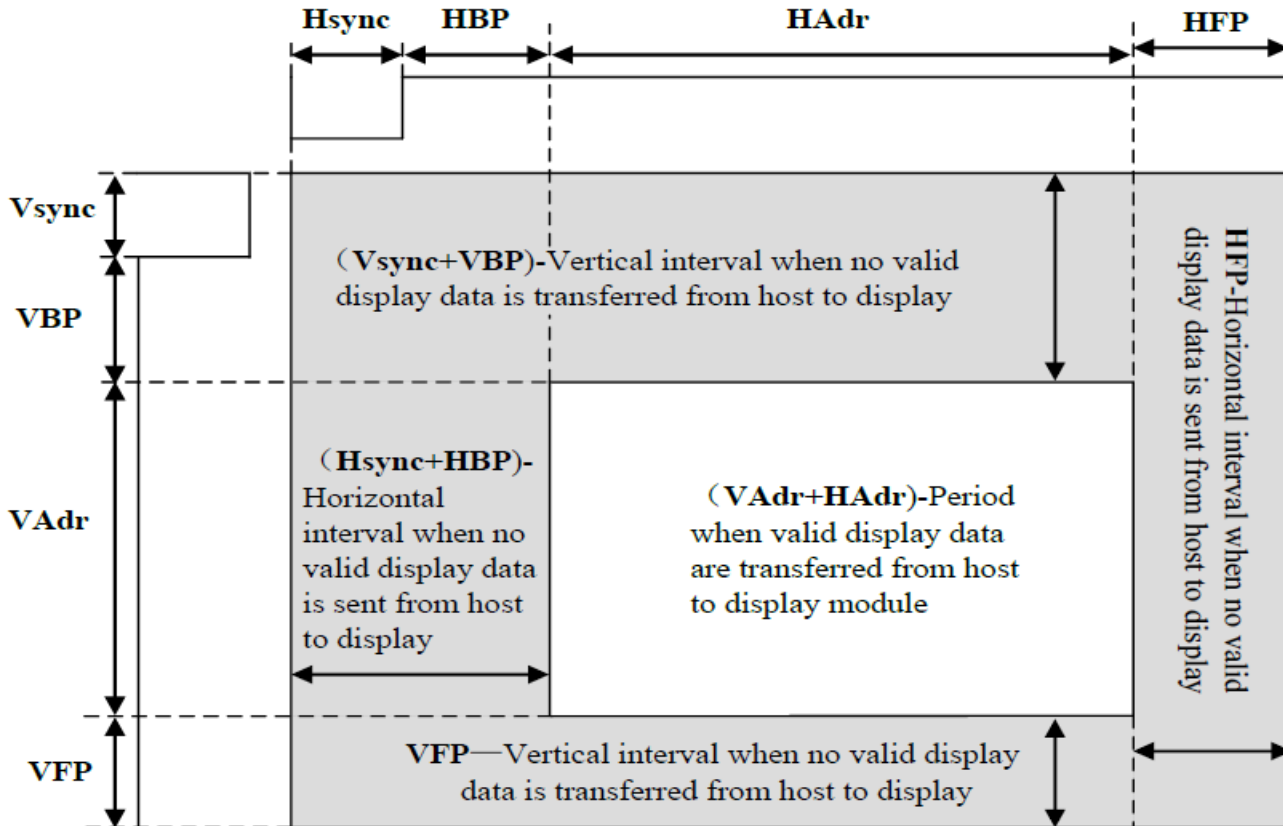

Figure define timing parameter for MIPI video operation

The NV3051F-L driver's MIPI-DSI is compliant with MIPI Alliance Standard for Display Serial Interface (DSI), Version 1.01.00 and D-PHY Version 1.00.00.

## Recommended Timing Values

HS Total	HFP	HBP	HS Pulse	VS Total	VFP	VBP	VS Pulse	PCLK Freq
600	46	44	2	1280	16	8	2	54 MHz

# LVDS Interface Mode

## Data Input Format

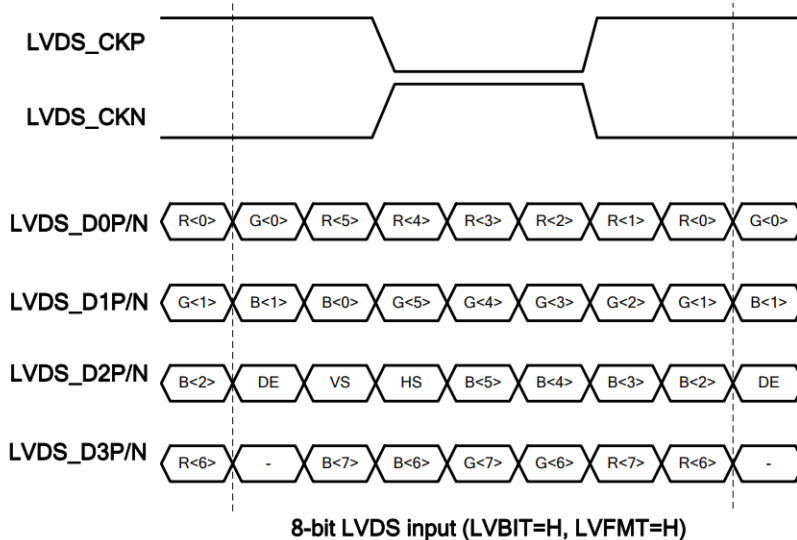
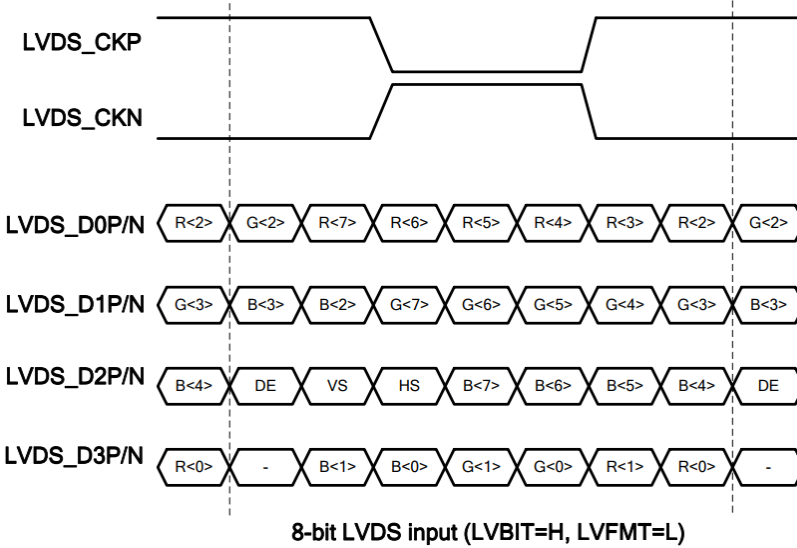
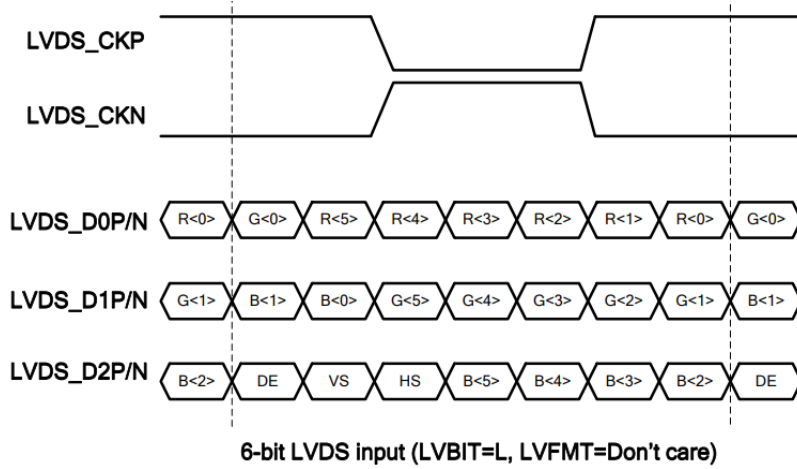

## Electrical Characteristics

TFT:

Item	Symbol	Condition	Min.	Typ.	Max.	Unit
Operating Temperature Range	T <sub>OP</sub>	Absolute Max	-20	-	+70	°C
Storage Temperature Range	T <sub>ST</sub>	Absolute Max	-30	-	+80	°C
Supply Voltage	V <sub>DD</sub>	-	2.5	3.3	3.6	V
Supply Current	I <sub>DD</sub>	V <sub>DD</sub> = 3.3V	-	55	72	mA
"H" Level input	V <sub>IH</sub>	-	0.7 * V <sub>DD</sub>	-	V <sub>DD</sub>	V
"L" Level input	V <sub>IL</sub>	-	GND	-	0.3* V <sub>DD</sub>	V
"H" Level output	V <sub>OH</sub>	-	0.8* V <sub>DD</sub>	-	V <sub>DD</sub>	V
"L" Level output	V <sub>OL</sub>	-	GND	-	0.2* V <sub>DD</sub>	V
Backlight Supply Current	I <sub>LED</sub>	-	150	170	190	mA
Backlight Supply Voltage	V <sub>LED</sub>	I <sub>LED</sub> = 170mA	15.6	18	19.2	V
Backlight Lifetime*	-	T <sub>OP</sub> = 25°C	30,000	-	-	Hrs.

\*Backlight lifetime is rated as Hours until **half-brightness**, under normal operating conditions. The LED of the backlight is driven by current drain; drive voltage is for reference only. Drive voltage must be selected to ensure backlight current drain is below MAX level stated.

### Capacitive Touch Panel:

Item	Symbol	Condition	Min.	Typ.	Max.	Unit
Operating Temperature Range	T <sub>OP</sub>	Absolute Max	-20	-	+70	°C
Storage Temperature Range	T <sub>ST</sub>	Absolute Max	-30	-	+80	°C
Supply Voltage	V <sub>DD</sub>	-	2.7	3.3	3.6	V
Supply Current – Operating	I <sub>DD</sub>	1 point input	6	12	24	mA
"H" Level input	V <sub>IH</sub>	-	0.7*V <sub>DD</sub>	-	V <sub>DD</sub>	V
"L" Level input	V <sub>IL</sub>	-	V <sub>SS</sub>	-	0.3*V <sub>DD</sub>	V
"H" Level output	V <sub>OH</sub>	IOH=0.1mA	0.7*V <sub>DD</sub>	-	V <sub>DD</sub>	V
"L" Level output	V <sub>OL</sub>	IOH=0.1mA	V <sub>SS</sub>	-	0.3*V <sub>DD</sub>	V

## MIPI Characteristics

LPDT Input Characteristics						
Pad Signal Voltage Range	V <sub>I</sub>	-	-50	-	1350	mV
Ground Shift	V <sub>GNDSH</sub>	-	-50	-	50	mV
Logic 0 Input Threshold	V <sub>IL</sub>	-	0	-	550	mV
Logic 1 Input Threshold	V <sub>IH</sub>	-	880	-	MV1P2	mV
Input Hysteresis	V <sub>HYST</sub>	-	25	-	-	mV
LPDT Output Characteristics						
Output Low Level	V <sub>OL</sub>	-	-50	-	50	mV
Output High Level	V <sub>OH</sub>	-	1.1	1.2	1.3	V
Logic 1 Contention Threshold	V <sub>ILCD, MIN</sub>	-	450	-	MV1P2	mV
Logic 0 Contention Threshold	V <sub>IHCD, MAX</sub>	-	0	-	200	mV
Output Impedance of LPDT	Z <sub>OLP</sub>	-	80	100	125	ohm
Hi-speed Input/Output Characteristics						
Single-end Input Low Voltage	V <sub>ILHS</sub>	-	-40	-	-	mV
Single-end Input High Voltage	V <sub>IHHS</sub>	-	-	-	460	mV
Common Mode Voltage	V <sub>CMRXDC</sub>	-	70	-	330	mV
Hi-speed Transmit Voltage	V <sub>OD</sub>	-	140	200	250	mV
Differential Input Impedance	Z <sub>ID</sub>	-	80	100	125	ohm



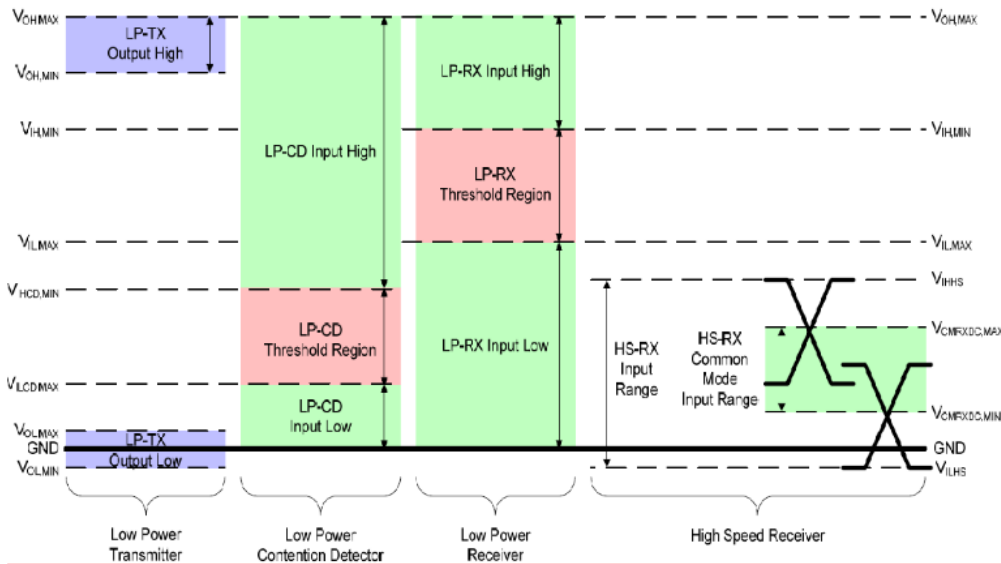

## LVDS Characteristics

Parameter	Symbol	Condition	Min.	Typ.	Max.	Unit
Differential Input High Threshold Voltage	$V_{RX, TH}$	$V_{RXVCM}=1.2V$	-	-	0.1	V
Differential Input Low Threshold Voltage	$V_{RX, TL}$		-0.1	-	-	V
Input Voltage Range (single-end)	$V_{RXIN}$		0	-	1.8	V
Differential Input Common Mode Voltage	$V_{RXVCM}$		$ VID /2$	1.2	1.8- $ VID /2$	V
Differential Input Voltage	$ VID $		0.2	-	0.6	V
Differential Input Leakage Current	$I_{LCLVDS}$		-10	-	10	$\mu A$
Differential Input Impedance	ZID		80	100	140	$\Omega$

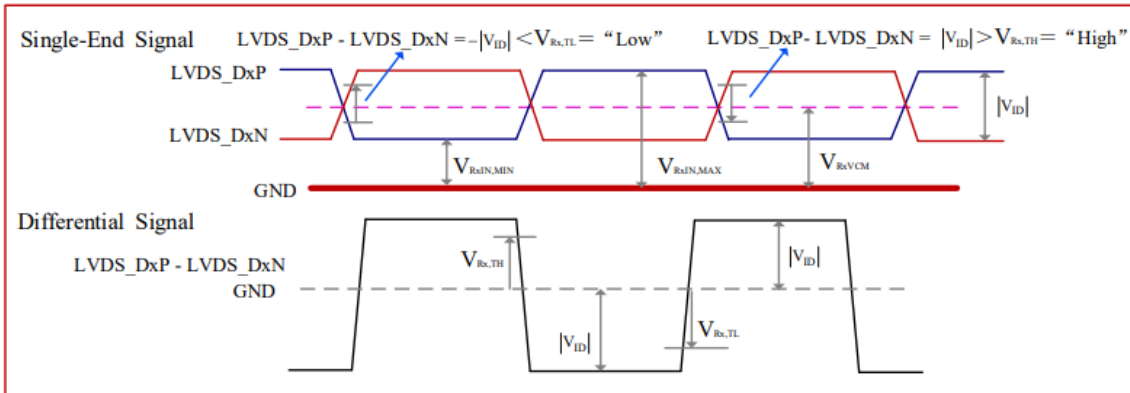

## Optical Characteristics

Item		Symbol	Condition	Min.	Typ.	Max.	Unit
Optimal Viewing Angles	Top	$\phi Y+$	-	-	85	-	°
	Bottom	$\phi Y-$		-	85	-	°
	Left	$\theta X-$		-	85	-	°
	Right	$\theta X+$		-	85	-	°
Contrast Ratio		CR	-	700	1000	-	-
Luminance		$L_V$	$I_{LED} = 170mA$	850	1020	-	cd/m <sup>2</sup>
Response Time (Rise + Fall)		$T_R + T_F$	$T_{OP} = 25^\circ C$	-	30	40	ms
Chromaticity	Red	$X_R$	-	0.577	0.627	0.677	-
		$Y_R$	-	0.283	0.333	0.383	-
	Green	$X_G$	-	0.239	0.289	0.339	-
		$Y_G$	-	0.522	0.572	0.622	-
	Blue	$X_B$	-	0.095	0.145	0.195	-
		$Y_B$	-	0.028	0.058	0.108	-
	White	$X_W$	-	0.214	0.264	0.314	-
		$Y_W$	-	0.228	0.278	0.328	-

## Driver/Controller Information

Built-in NV3051F-L Source Driver: <https://support.newhavendisplay.com/hc/en-us/articles/25416096369431-NV3051F-L>

Built-in FT5426G Controller: <https://support.newhavendisplay.com/hc/en-us/articles/17688730921367-FT5426G>

## Capacitive Touch Panel Registers

Register No.	Access	Register Name	Bits	Value	Description
01h	RO	Gesture ID	[7:0]	1Ch	Swipe Up
				14h	Swipe Down
				10h	Swipe Left
				18h	Swipe Right
				48h	Zoom In
				49h	Zoom Out
				00	No gesture
02h	RO	Touch Points	[7:0]	0-Ah	0: No touch detected A: 10 touch points detected
03h	RO	TOUCH1_Event_Flag	[7:6]	0	Put Down
				1	Put Up
				2	Contact
				3	Reserved
03h	RO	TOUCH1_XH	[3:0]	0-1	Upper 4 bits of X touch coordinate
04h	RO	TOUCH1_XL	[7:0]	00 – FFh	Lower 8 bits of X touch coordinate
05h	RO	TOUCH1_YH	[3:0]	0-1	Upper 4 bits of Y touch coordinate
06h	RO	TOUCH1_YL	[7:0]	00 – FFh	Lower 8 bits of Y touch coordinate
07h	RO	TOUCH1_Weight	[7:0]		Touch Weight
08h	RO	TOUCH1_Misc	[3:0]	00-0Fh	Touch Area
09h	RO	TOUCH2_Event_Flag	[7:6]	0	Put Down
				1	Put Up
				2	Contact
				3	Reserved
09h	RO	TOUCH1_XH	[3:0]	0-1	Upper 4 bits of X touch coordinate
0Ah	RO	TOUCH2_XL	[7:0]	00 – FFh	Lower 8 bits of X touch coordinate
0Bh	RO	TOUCH2_YH	[3:0]	0-1	Upper 4 bits of Y touch coordinate
0Ch	RO	TOUCH2_YL	[7:0]	00 – FFh	Lower 8 bits of Y touch coordinate
0Dh	RO	TOUCH2_Weight	[7:0]		Touch Weight
0Eh	RO	TOUCH2_Misc	[3:0]	00-0Fh	Touch Area
0Fh	RO	TOUCH3_Event_Flag	[7:6]	0	Put Down
				1	Put Up
				2	Contact
				3	Reserved
0Fh	RO	TOUCH3_XH	[3:0]	0-1	Upper 4 bits of X touch coordinate
10	RO	TOUCH3_XL	[7:0]	00 – FFh	Lower 8 bits of X touch coordinate
11h	RO	TOUCH3_YH	[3:0]	0-1	Upper 4 bits of Y touch coordinate
12h	RO	TOUCH3_YL	[7:0]	00 – FFh	Lower 8 bits of Y touch coordinate
13h	RO	TOUCH3_Weight	[7:0]		Touch Weight
14h	RO	TOUCH3_Misc	[3:0]	00-0Fh	Touch Area
15h	RO	TOUCH4_Event_Flag	[7:6]	0	Put Down
				1	Put Up
				2	Contact
				3	Reserved
15h	RO	TOUCH4_XH	[3:0]	0-1	Upper 4 bits of X touch coordinate
16h	RO	TOUCH4_XL	[7:0]	00 – FFh	Lower 8 bits of X touch coordinate
17h	RO	TOUCH4_YH	[3:0]	0-1	Upper 4 bits of Y touch coordinate
18h	RO	TOUCH4_YL	[7:0]	00 – FFh	Lower 8 bits of Y touch coordinate
1Ah	RO	TOUCH4_Misc	[3:0]	00-0Fh	Touch Area
1Bh	RO	TOUCH5_Event_Flag	[7:6]	0	Put Down
				1	Put Up
				2	Contact
				3	Reserved

Register No.	Access	Register Name	Bits	Value	Description
1Bh	RO	TOUCH5_XH	[3:0]	0 -1	Upper 4 bits of X touch coordinate
1Ch	RO	TOUCH5_XL	[7:0]	00 – FFh	Lower 8 bits of X touch coordinate
1Dh	RO	TOUCH5_YH	[3:0]	0 -1	Upper 4 bits of Y touch coordinate
1Eh	RO	TOUCH5_YL	[7:0]	00 – FFh	Lower 8 bits of Y touch coordinate
1Fh	RO	TOUCH5_Weight	[7:0]		Touch Weight
20	RO	TOUCH5_Misc	[3:0]	00-0Fh	Touch Area
21h	RO	TOUCH6_Event_Flag	[7:6]	0	Put Down
				1	Put Up
				2	Contact
				3	Reserved
21h	RO	TOUCH6_XH	[3:0]	0 -1	Upper 4 bits of X touch coordinate
22h	RO	TOUCH6_XL	[7:0]	00 – FFh	Lower 8 bits of X touch coordinate
23h	RO	TOUCH6_YH	[3:0]	0 -1	Upper 4 bits of Y touch coordinate
24h	RO	TOUCH6_YL	[7:0]	00 – FFh	Lower 8 bits of Y touch coordinate
25h	RO	TOUCH6_Weight	[7:0]		Touch Weight
26h	RO	TOUCH6_Misc	[3:0]	00-0Fh	Touch Area
27h	RO	TOUCH7_Event_Flag	[7:6]	0	Put Down
				1	Put Up
				2	Contact
				3	Reserved
27h	RO	TOUCH7_XH	[3:0]	0 -1	Upper 4 bits of X touch coordinate
28h	RO	TOUCH7_XL	[7:0]	00 – FFh	Lower 8 bits of X touch coordinate
29h	RO	TOUCH7_YH	[3:0]	0 – 1	Upper 4 bits of Y touch coordinate
2Ah	RO	TOUCH7_YL	[7:0]	00 – FFh	Lower 8 bits of Y touch coordinate
2Bh	RO	TOUCH7_Weight	[7:0]		Touch Weight
2Ch	RO	TOUCH7_Misc	[3:0]	00-0Fh	Touch Area
2Dh	RO	TOUCH8_Event_Flag	[7:6]	0	Put Down
				1	Put Up
				2	Contact
				3	Reserved
2Dh	RO	TOUCH8_XH	[3:0]	0 – 1	Upper 4 bits of X touch coordinate
2Eh	RO	TOUCH8_XL	[7:0]	00 – FFh	Lower 8 bits of X touch coordinate
2Fh	RO	TOUCH8_YH	[3:0]	0 – 1	Upper 4 bits of Y touch coordinate
30	RO	TOUCH8_YL	[7:0]	00 – FFh	Lower 8 bits of Y touch coordinate
31h	RO	TOUCH8_Weight	[7:0]		Touch Weight
32h	RO	TOUCH8_Misc	[3:0]	00-0Fh	Touch Area
33h	RO	TOUCH9_Event_Flag	[7:6]	0	Put Down
				1	Put Up
				2	Contact
				3	Reserved
33h	RO	TOUCH9_XH	[3:0]	0 – 1	Upper 4 bits of X touch coordinate
34h	RO	TOUCH9_XL	[7:0]	00 – FFh	Lower 8 bits of X touch coordinate
35h	RO	TOUCH9_YH	[3:0]	0 – 1	Upper 4 bits of Y touch coordinate
36h	RO	TOUCH9_YL	[7:0]	00 – FFh	Lower 8 bits of Y touch coordinate
37h	RO	TOUCH9_Weight	[7:0]		Touch Weight
38h	RO	TOUCH9_Misc	[3:0]	00 – 0Fh	Touch Area
39h	RO	TOUCH10_Event_Flag	[7:6]	0	Put Down
				1	Put Up
				2	Contact
				3	Reserved
39h	RO	TOUCH10_XH	[3:0]	0 – 1	Upper 4 bits of X touch coordinate
3Ah	RO	TOUCH10_XL	[7:0]	00 – FFh	Lower 8 bits of X touch coordinate
3Bh	RO	TOUCH10_YH	[3:0]	0 – 1	Upper 4 bits of Y touch coordinate
3Ch	RO	TOUCH10_YL	[7:0]	00 - FFh	Lower 8 bits of Y touch coordinate



Register No.	Access	Register Name	Bits	Value	Description
3Dh	RO	TOUCH10_Weight	[7:0]	00-FFh	Touch Weight
3Eh	RO	TOUCH10_Misc	[3:0]	00-0Fh	Touch Area
A1h	RO	ID_G_LIB_VERSION_H	[7:0]	00-FFh	App library version high-byte Default: 0
A2h	RO	ID_G_LIB_VERSION_L	[7:0]	00-FFh	App library version low-byte Default: 1h
A3h	RO	ID_G_CHIPER_HIGH	[7:0]	00-FFh	Chip Vendor ID Default: 0x54
A6h	RO	ID_G_FIRMID	[7:0]	00-FFh	Firmware ID Number Default: 1h
A8h	RO	ID_G_VENODRID	[7:0]	00-FFh	CTPM Vendor's Chip ID Default: 79h

# Timing Characteristics- TFT Display

## SPI Interface

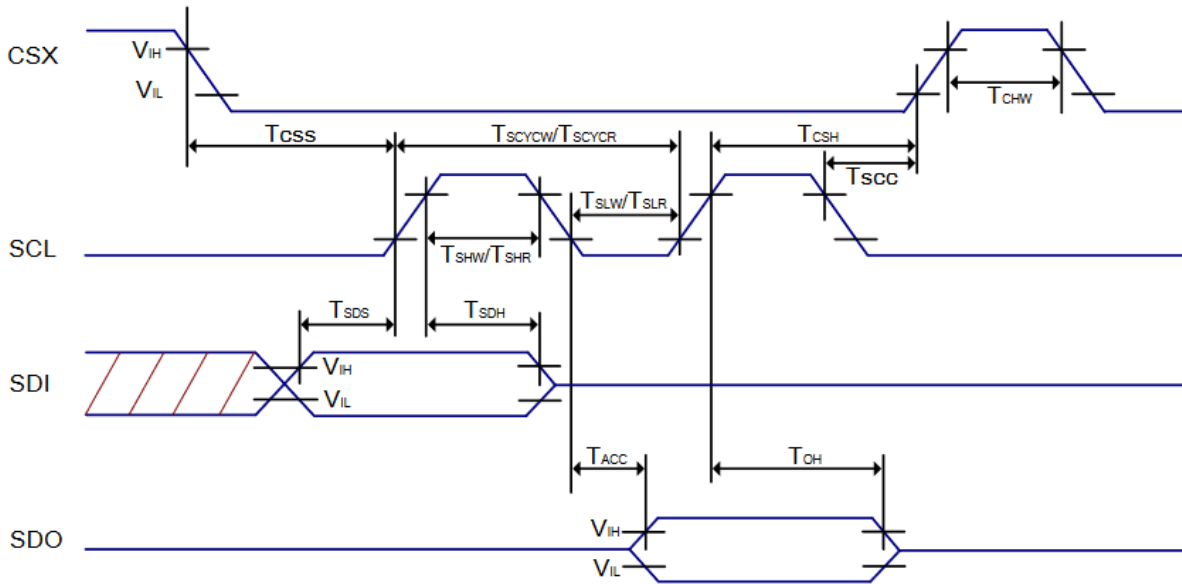

Signal	Symbol	Parameter	MIN	MAX	Unit	Description
CSX	T <sub>CSS</sub>	Chip select setup time	15	-	ns	-
	T <sub>CSH</sub>	Chip select hold time	15	-	ns	
	T <sub>SCC</sub>	Chip select setup time	20	-	ns	
	T <sub>CHW</sub>	Chip "H" pulse width	40	-	ns	
SCL	T <sub>SCYCW</sub>	Serial clock cycle (Write)	66	-	ns	-
	T <sub>SHW</sub>	SCL "H" pulse width (Write)	10	-	ns	
	T <sub>SLW</sub>	SCL "L" pulse width (Write)	10	-	ns	
	T <sub>SCYCR</sub>	Serial clock cycle (Read)	150	-	ns	-
	T <sub>SHR</sub>	SCL "H" pulse width (Read)	60	-	ns	
	T <sub>SLR</sub>	SCL "L" pulse width (Read)	60	-	ns	
SDI	T <sub>SDS</sub>	Data setup time	10	-	ns	For maximum C <sub>L</sub> =30pf For minimum C <sub>L</sub> =8pf
	T <sub>SDH</sub>	Data hold time	10	-	ns	
	T <sub>ACC</sub>	Access time	10	50	ns	
	T <sub>OH</sub>	Output disable time	15	50	ns	

## MIPI DSI Interface

### High Speed Mode

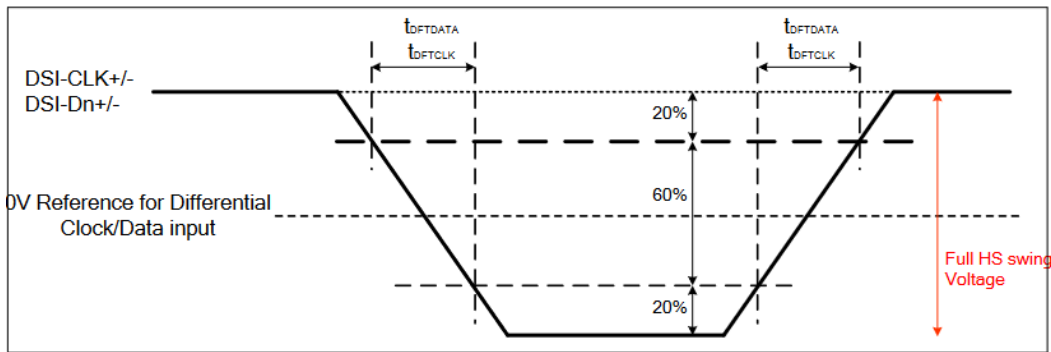
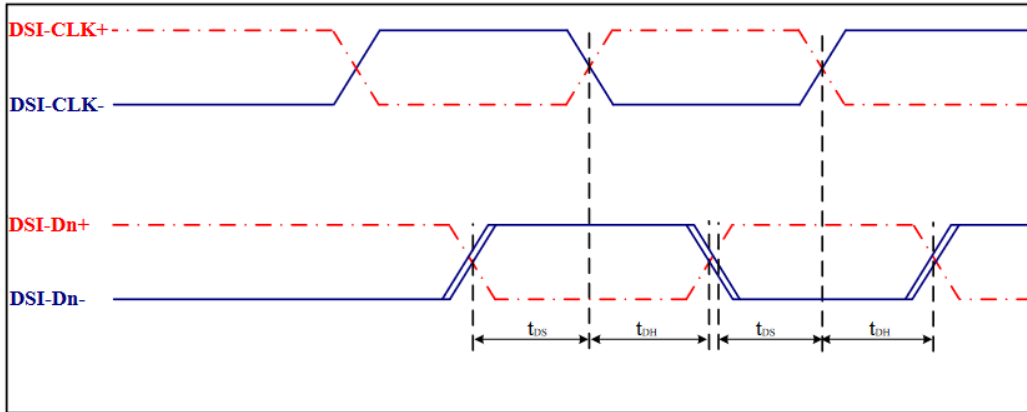
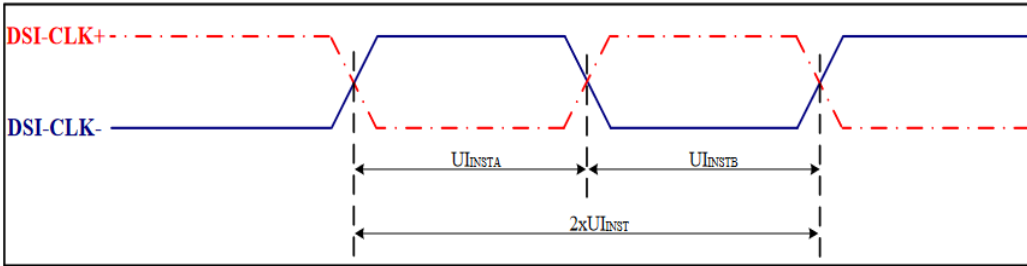

Parameter	Symbol	Parameter	Specification			Unit
			MIN	TYP	MAX	
<b>High Speed Mode</b>						
DSI-CLK+/-	$2X_{uiinst}$	Double UI instantaneous	2.22	-	25	ns
DSI-CLK+/-	$U_{INSTA}, U_{INSTB}$	UI instantaneous Halfs	1.11	-	12.5	ns
DSI-Dn+/-	$T_{ds}$	Data to clock setup time	0.15	-	-	UI
DSI-Dn+/-	$T_{dh}$	Data to clock hold time	0.15	-	-	UI
DSI-CLK+/-	$T_{drtclk}$	Differential rise time for clock	150	-	0.3UI	ps
DSI-Dn+/-	$T_{drtdata}$	Differential rise time for data	150	-	0.3UI	ps
DSI-CLK+/-	$T_{dftclk}$	Differential fall time for clock	150	-	0.3UI	ps
DSI-Dn+/-	$T_{dftdata}$	Differential fall time for data	150	-	0.3UI	ps

### Low Power Mode

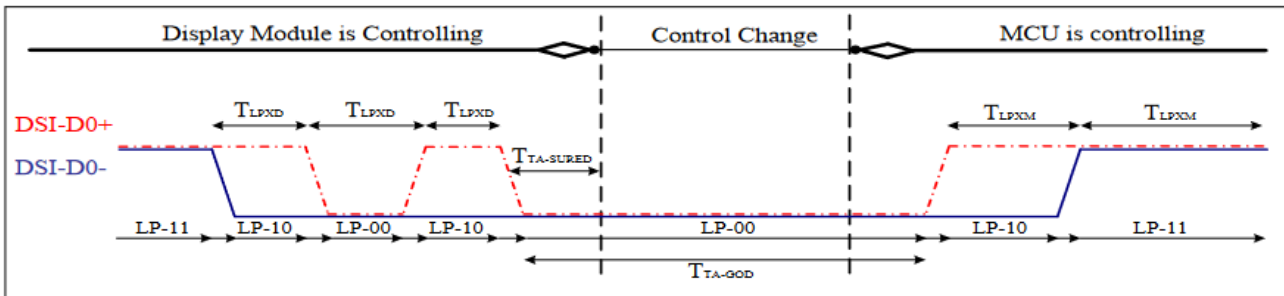
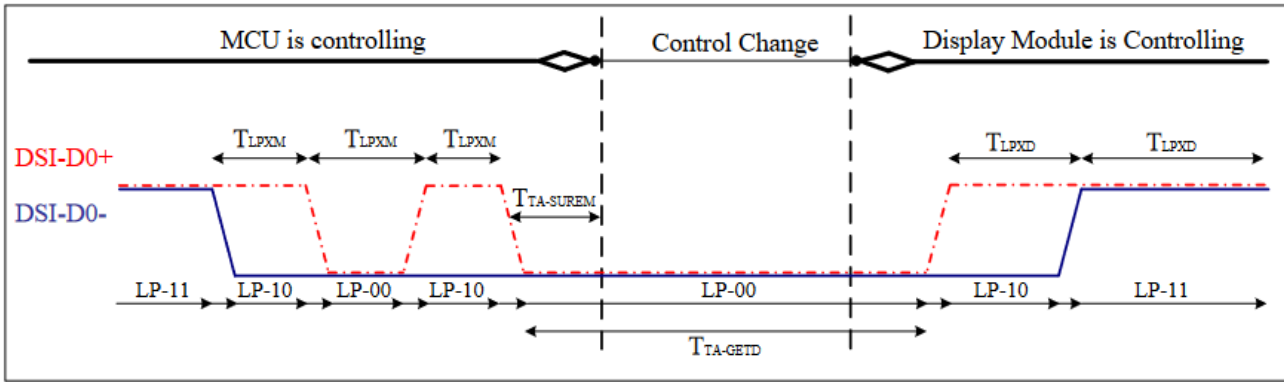

Parameter	Symbol	Parameter	Specification			Unit
			MIN	TYP	MAX	
<b>Low Power Mode</b>						
DSI-D0+/-	TLPXM	Length of LP-00, LP-01, LP-10 or LP-11 periods MPU Display Module	50	-	-	ns
DSI- D0+/-	TLPXD	Length of LP-00, LP-01, LP-10 or LP-11 periods Display Modulen MPU	58	-	-	ns
DSI- D0+/-	TTA-SURED	Time-out before the MPU start driving	TLPXD	-	2XTLPXD	ns
DSI- D0+/-	TTA-GETD	Time to drive LP-00 by display module	5XTLPXD	-	-	ns
DSI- D0+/-	TTA-GOD	Time to drive LP-00 after turnaround request – MPU	4XTLPXD	-	-	ns
DSI- D0+/-	Ratio TLPX	Ratio of TLPXM / TLPXD between MCU and display module	2/3	-	3/2	

## Bursts

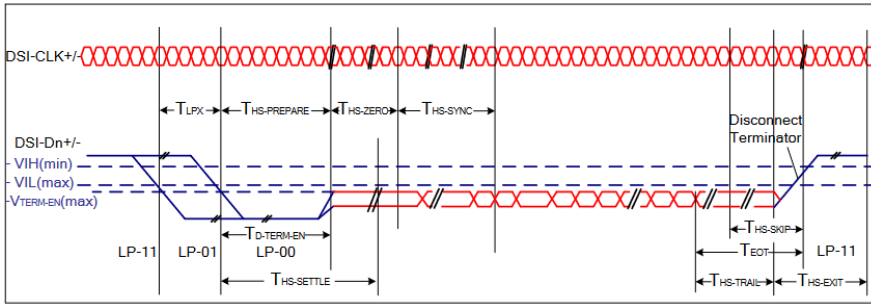

Figure: High Speed Data Transmission Bursts

Parameter	Symbol	Parameter	Specification			Unit
			MIN	TYP	MAX	
<b>High Speed Data Transmission Bursts</b>						
DSI-Dn+/-	TLPX	Length of any low-power state period	50	-	-	ns
DSI- Dn+/-	THS- PREPARE	Time to drive LP-00 to prepare for HS transmission	40ns+4UI	-	85ns+6UI	ns
DSI- Dn+/-	THS- PREPARE+THS- ZERO	THS-PREPARE+time to drive HS-0 before the sync sequence	145ns+10UI	-	-	ns
DSI- Dn+/-	TD-TERM- EN	Time to enable Data Lane receiver line termination measured from when Dn crosses VIL(max)	Time for Dn to reach VTERM-EN	-	35ns+4UI	ns
DSI- Dn+/-	THS-SKIP	Time-out at RX to ignore transition period of EoT	40	-	55ns+4UI	ns
DSI- Dn+/-	THS-TRAIL	Time to drive flipped differential state after last payload data bit of a HS transmission burst	max (8UI, 60ns+4UI)	-	-	ns
DSI- Dn+/-	THS-EXIT	Time to drive LP-11 after HS burst	100	-	-	ns
DSI- Dn+/-	TeoT	Time from start of THS-TRAIL period to start of LP-11 state	-	-	105ns+12UI	ns

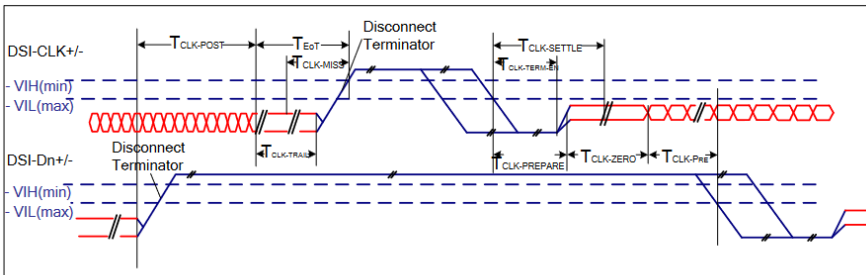
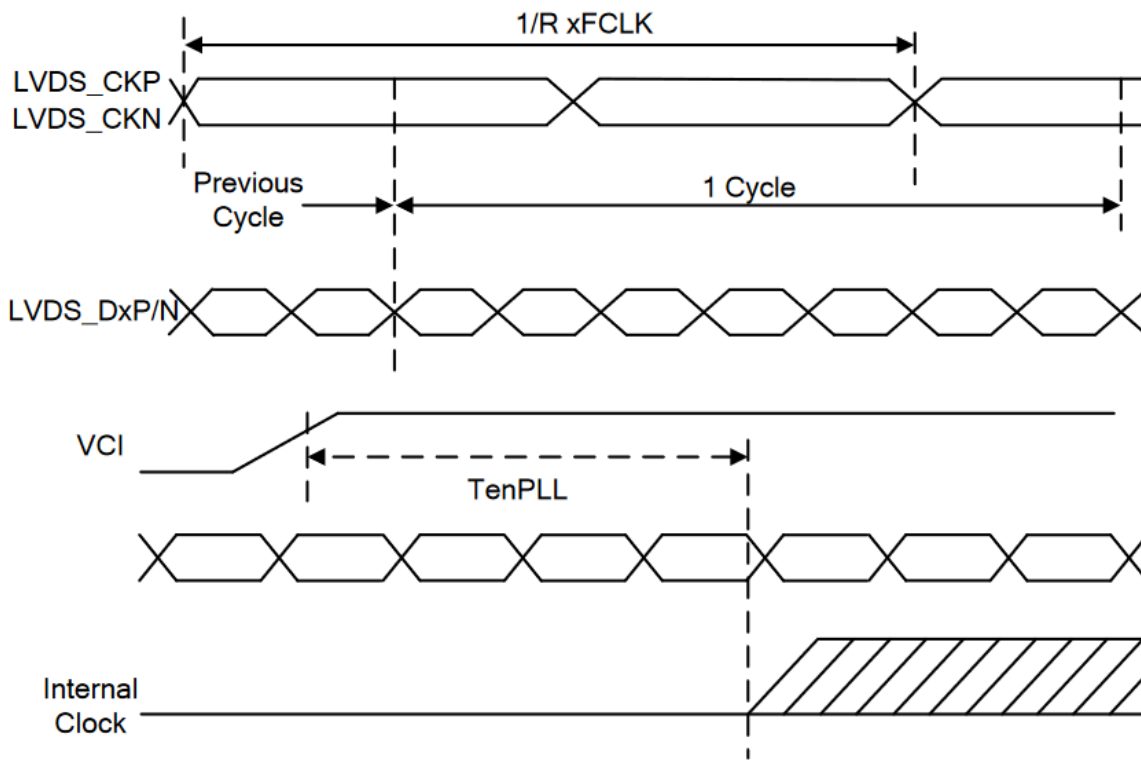

Figure: Switching the clock Lane between clock Transmission and Low Power Mode

Parameter	Symbol	Parameter	Specification			Unit
			MIN	TYP	MAX	
<b>Switching the clock Lane between clock Transmission and Low Power Mode</b>						
DSI-CLK+/-	TCLK-POST	Time that the transmitter shall continue sending HS clock after the last associated Data Lane has transitioned to LP mode	60ns+52UI	-	-	ns
DSI-CLK+/-	TCLK-PRE	Time that the HS clock shall be driven prior to any associated Data Lane beginning the transition from LP to HS mode	8	-	-	UI
DSI-CLK+/-	TCLK-PREPARE	Time to drive LP-00 to prepare for HS clock transmission	38	-	95	ns
DSI-CLK+/-	TCLK-TERM- EN	Time to enable Clock Lane receiver line termination measured from when Dn crosses VIL(max)	Time for Dn to reach VTERM-EN	-	38	ns
DSI- CLK+/-	TCLK-PREPARE +TCLK-ZERO	TCLK-PREPARE + time for lead HS-0 drive period before starting Clock	300	-	-	ns
DSI- CLK+/-	TCLK-TRAIL	Time to drive HS differential state after last payload clock bit of a HS transmission burst	60	-	-	ns
DSI-CLK+/-	TeoT	Time from start of TCLK-TRAIL period to start of LP-11 state	-	-	105ns+12UI	ns

**LVDS Interface**

Parameter	Symbol	Condition	Min.	Typ.	Max.	Unit
Clock Frequency	RxFCLK	-	30	-	71	MHz
Input data skew margin	TRSKM	VID =200mV RxVCM=1.2V RxFCLK=71MHz	500	-	-	ps
Clock High Time	TLVCH	-	-	4/(7*RxFCLK)	-	ns
Clock Low Time	TLVCL	-	-	3/(7*RxFCLK)	-	ns
PLL wake-up-time	TenPLL	-	-	-	150	us



Parameter	Symbol	Min.	Typ.	Max.	Units	Condition
Modulation Frequency	SSCMF	23	-	93	KHz	
Modulation Rate	SSCMR	-	-	+3	%	

## Reset Timing

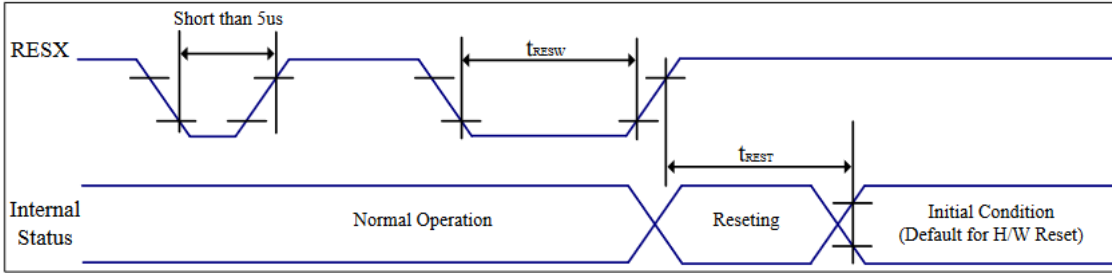

Symbol	Parameter	Related Pins	MIN	TYP	MAX	Note	Unit
$T_{resw}$	*1) Reset low pulse width	RESX	10	-	-	-	us
$T_{rest}$	*2) Reset complete time	-	-	-	5	When reset applied during Sleep in mode	ms
		-	-	-	120	When reset applied during Sleep out mode	ms

## Power ON/OFF Sequence

If RESX line is held Low (and stable) by the host during Power On, then the RESX must be held low for minimum 10us after VCI has been applied

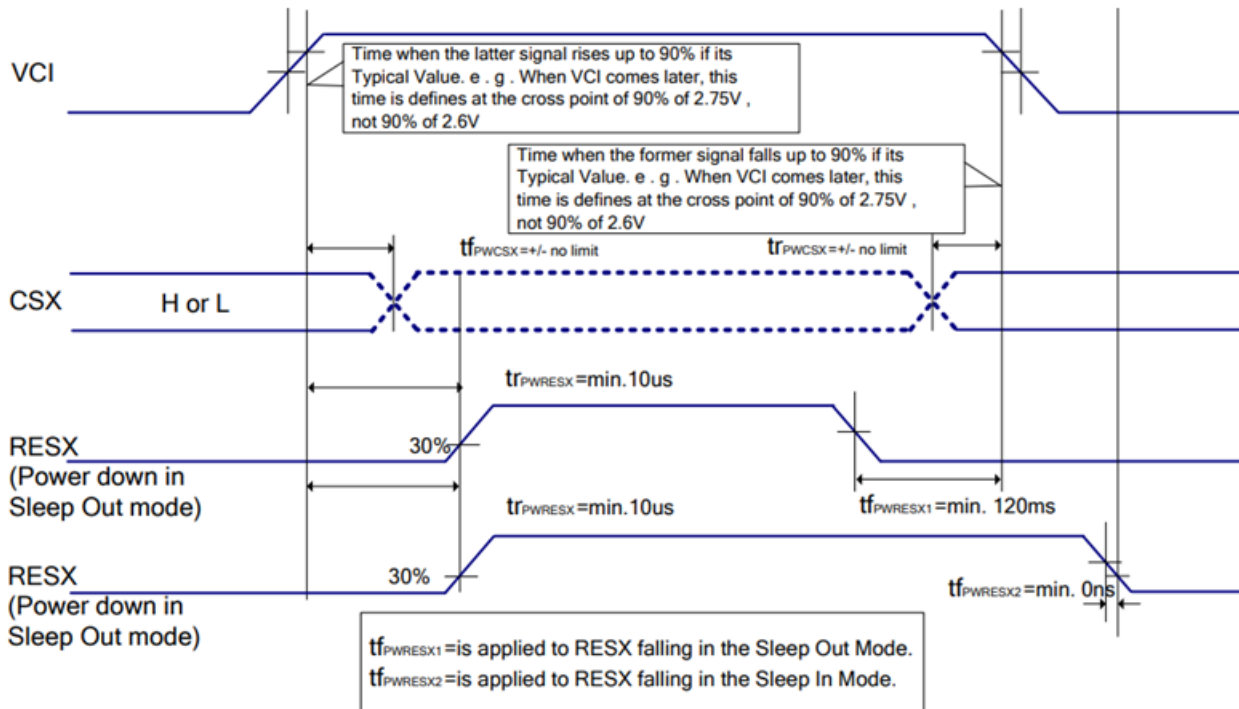

## Timing Characteristics – Capacitive Touch Panel

### Data Transfer Format

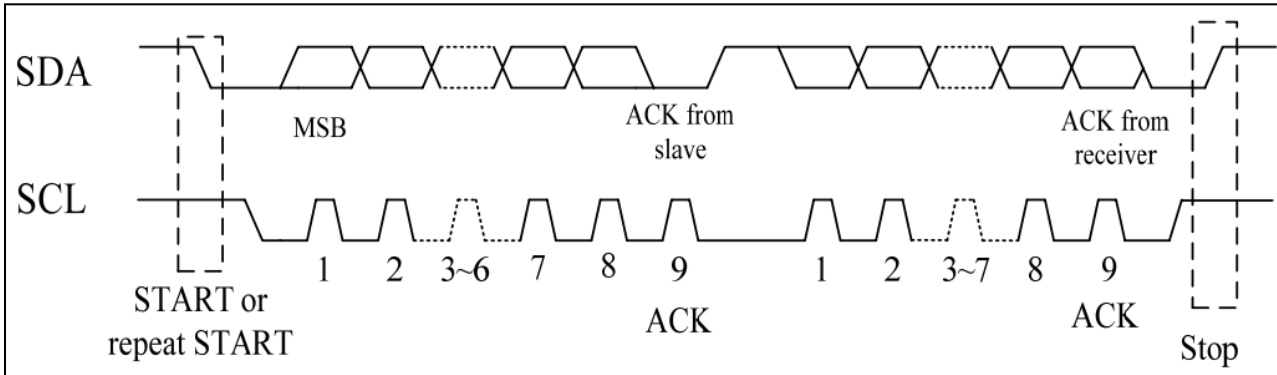

Parameter	Min	Max	Unit
SCL Frequency	0	400	KHz
Bus free time between a STOP & START condition	1.3	-	$\mu$ s
Hold time Repeated START condition	0.6	-	$\mu$ s
Data Setup Time	100	-	ns
Setup time for a repeated START condition	0.6	-	$\mu$ s
Setup time for a STOP condition	0.6	-	$\mu$ s

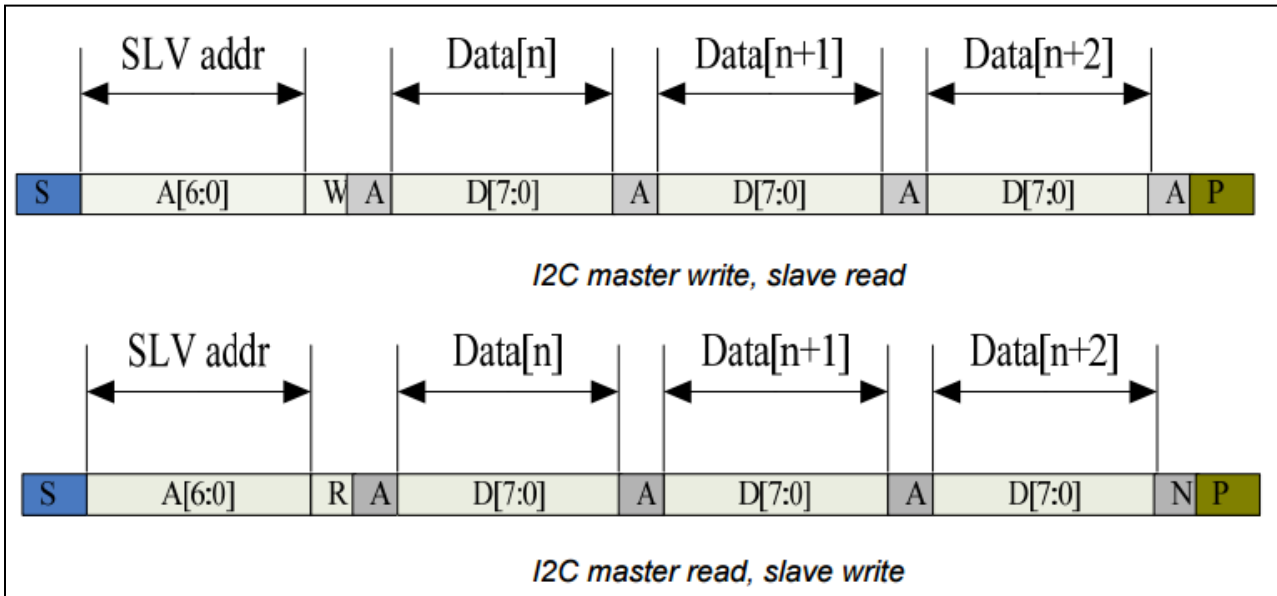

## Power ON/Reset Sequence

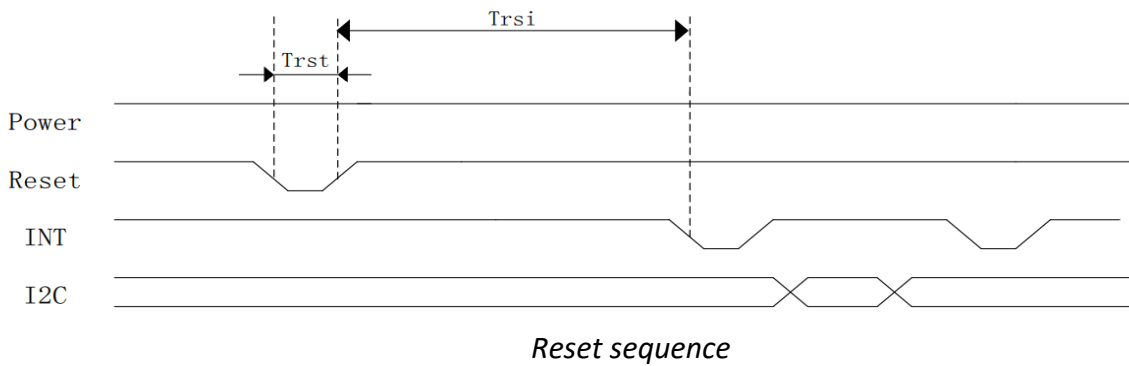
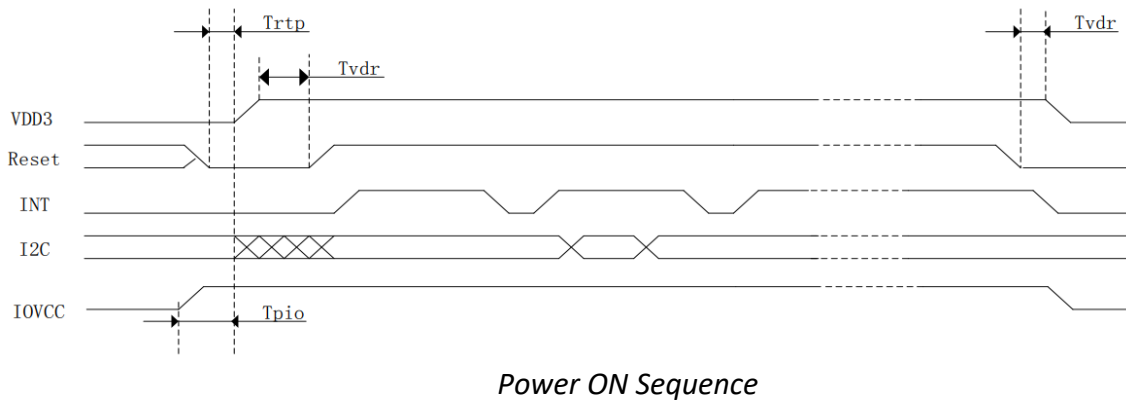
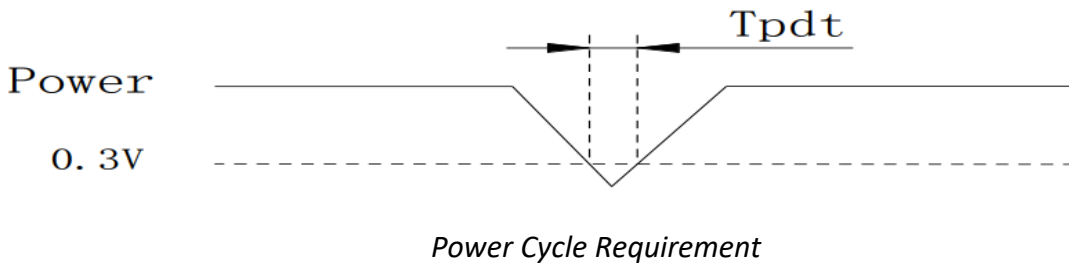
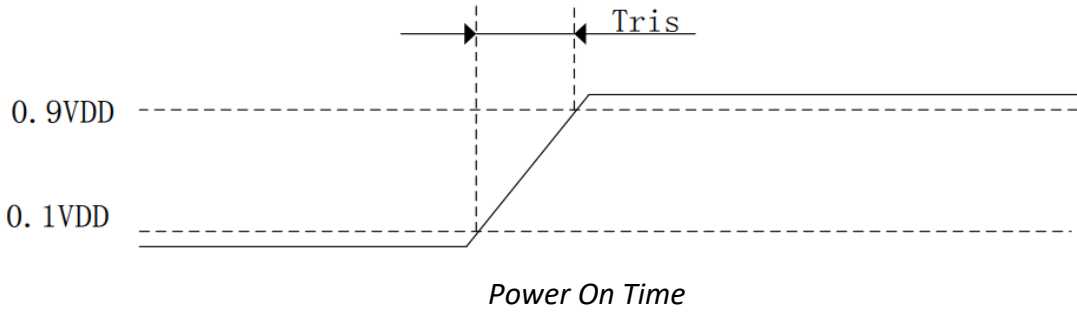

Parameter	Description	Min	Max	Unit
$T_{ris}$	Rise time from 0.1V <sub>DD</sub> to 0.9V <sub>DD</sub>	-	5	ms
$T_{pd\ t}$	Time of the voltage of supply being below 0.3V	5	-	ms
$T_{rtp}$	Time of resetting to be low before powering on	100	-	μs
$T_{pon}$	Time to start reporting after power on	-	200	ms
$T_{vdr}$	Reset time after applying V <sub>DD</sub>	1	-	ms
$T_{rsi}$	Time to start reporting after reset	-	200	ms
$T_{rst}$	Reset Time	1	-	ms

\*If Reset is tied to V<sub>CC</sub> data corruption can occur.

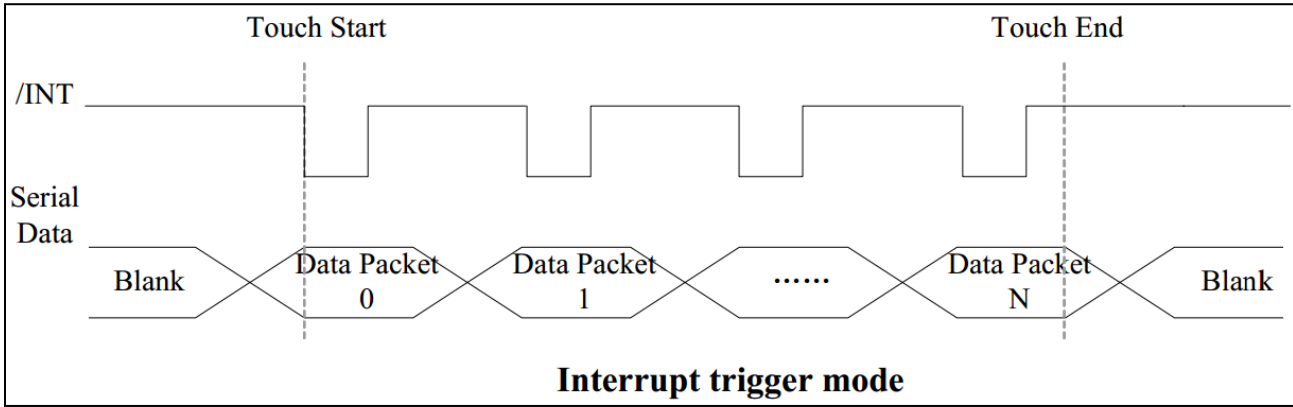

### Sample code to read touch data:

```
i2c_start();
i2c_tx(0x70); //Slave Address (Write)
i2c_tx(0x00); //Start reading address
i2c_stop();
```

```
i2c_start();
i2c_tx(0x71); //Slave Address (Read)
for(i=0x00;i<0x1F;i++)
{touchdata_buffer[i] = i2c_rx(1);}
i2c_stop();
```

### Sample code to overwrite default register values:

```
i2c_start();
i2c_tx(0x70); //Slave Address (Write)
i2c_tx(0xA4); //ID_G_Mode
i2c_tx(0x01); //Disable interrupt status to host
i2c_stop();
```

## Quality Information

Test Item	Content of Test	Test Condition	Note
High Temperature storage	Endurance test applying the high storage temperature for a long time.	+80°C , 240hrs	2
Low Temperature storage	Endurance test applying the low storage temperature for a long time.	-30°C , 240hrs	1,2
High Temperature Operation	Endurance test applying the electric stress (voltage & current) and the high thermal stress for a long time.	+70°C 240hrs	2
Low Temperature Operation	Endurance test applying the electric stress (voltage & current) and the low thermal stress for a long time.	-20°C , 240hrs	1,2
High Temperature / Humidity Storage	Endurance test applying the high thermal with high humidity stress for a long time.	+60°C , 90% RH , 240hrs	1,2
Thermal Shock resistance	Endurance test applying the electric stress (voltage & current) during a cycle of low and high thermal stress.	-30°C ← 25°C → +80°C (30 min ← 3 min → 30min) 100 cycles	
Static electricity test	Endurance test applying electric static discharge.	Air: ±8kV 150pF/330Ω ; Contact: ±4kV 150pF/330Ω For 10 times each.	

**Note 1:** No condensation to be observed.

**Note 2:** Conducted after 4 hours of storage at 25°C, 0%RH.

**Note 3:** Test performed on product itself, not inside a container.