

**Product Specification**

---

# NHD-2.4-240320AF-CSXP-T

## TFT Liquid Crystal Display

<b>NHD-</b>	Newhaven Display
<b>2.4-</b>	2.4" Diagonal
<b>240320-</b>	240xRGBx320 Pixels
<b>AF-</b>	Model
<b>C-</b>	Built-in Controller
<b>S-</b>	High Brightness, White LED Backlight
<b>X-</b>	TFT
<b>P-</b>	IPS, Wide Temperature
<b>T-</b>	4-Wire Resistive Touch Panel

## Table of Contents

Document Revision History.....	2
Mechanical Drawing .....	3
Pin Description .....	4
Interface Selection.....	4
Wiring Diagram .....	5
Electrical Characteristics .....	6
Optical Characteristics .....	6
Touch Panel Characteristic.....	7
Controller Information.....	7
Timing Characteristics for TFT .....	8
Example Initialization Code.....	11
Quality Information.....	12

---

## Additional Resources

- **Support Forum:** <https://support.newhavendisplay.com/hc/en-us/community/topics>
- **GitHub:** <https://github.com/newhavendisplay>
- **Example Code:** <https://support.newhavendisplay.com/hc/en-us/categories/4409527834135-Example-Code/>
- **Knowledge Center:** [https://www.newhavendisplay.com/knowledge\\_center.html](https://www.newhavendisplay.com/knowledge_center.html)
- **Quality Center:** [https://www.newhavendisplay.com/quality\\_center.html](https://www.newhavendisplay.com/quality_center.html)
- **Precautions for using LCDs/LCMs:** <https://www.newhavendisplay.com/specs/precautions.pdf>
- **Warranty / Terms & Conditions:** <https://www.newhavendisplay.com/terms.html>



## Document Revision History

Revision	Date	Description	Changed By
-	09/18/2023	Initial Release	KL

# Mechanical Drawing

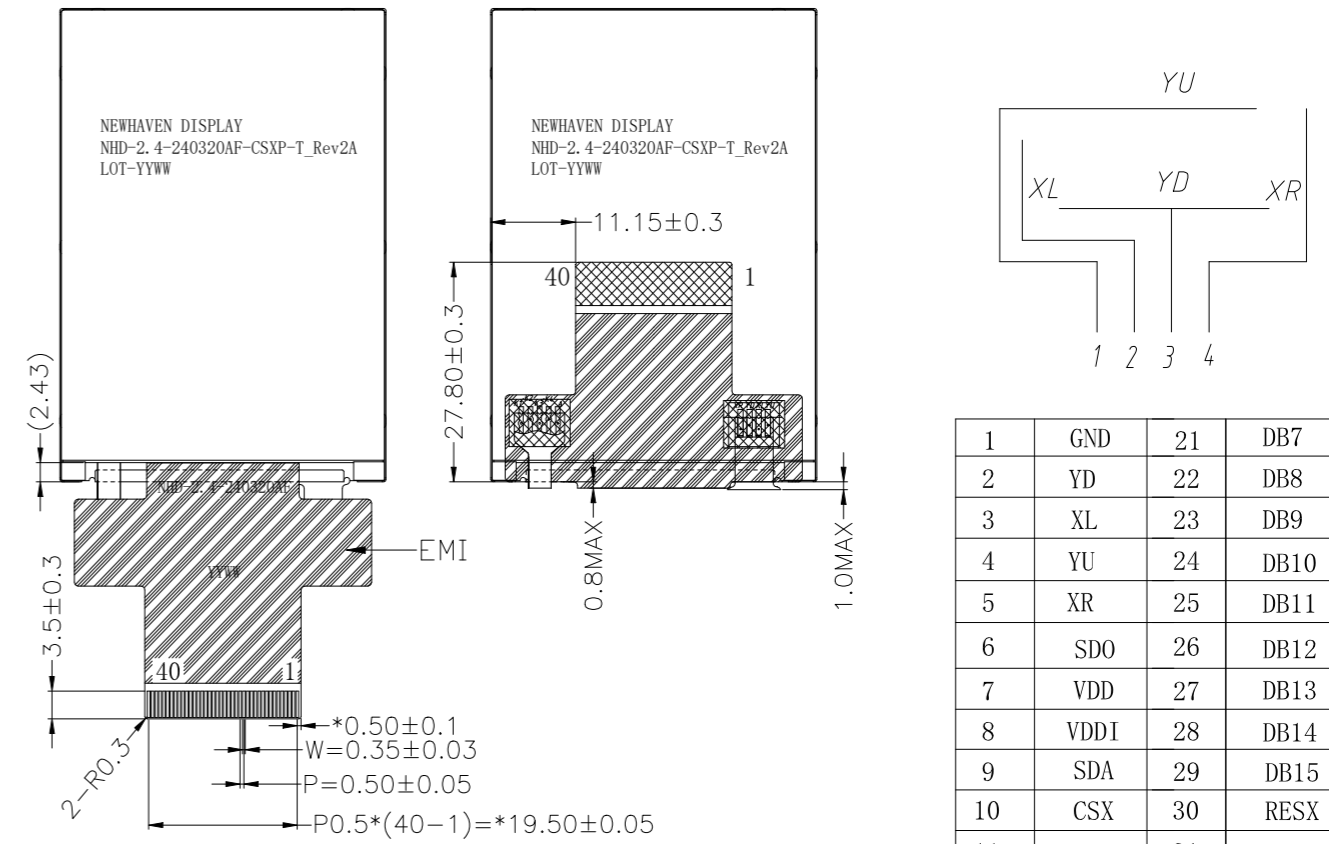
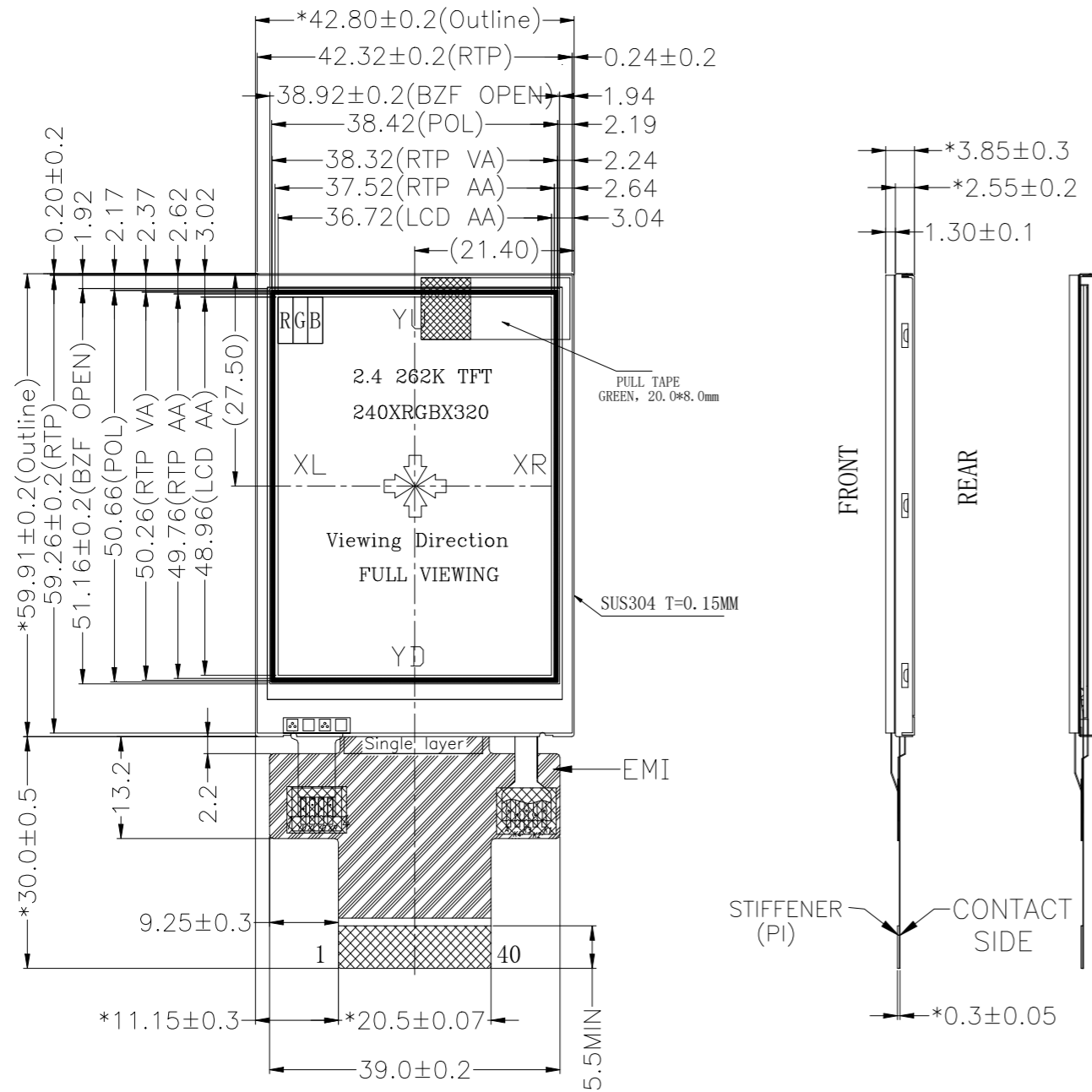

1	GND	21	DB7
2	YD	22	DB8
3	XL	23	DB9
4	YU	24	DB10
5	XR	25	DB11
6	SDO	26	DB12
7	VDD	27	DB13
8	VDDI	28	DB14
9	SDA	29	DB15
10	CSX	30	RESX
11	DCX	31	IMO
12	WRX	32	IM2
13	RDX	33	GND
14	DB0	34	LEDK1
15	DB1	35	LEDK2
16	DB2	36	LEDK3
17	DB3	37	LEDK4
18	DB4	38	LEDA
19	DB5	39	GND
20	DB6	40	TE

Product Description: 2.4" 240x320 IPS TFT w/ Resistive Touch

1. Driver IC: ST7789VI
2. Interface: 8/16-bit 8080 Parallel RGB TFT, 3-line SPI RTP
3. Power Requirement: 3.3V TFT, 3.0V/160mA Backlight
4. Optical Features: Normally Black, Transmissive, Anti-Glare, 960cd/m<sup>2</sup>
5. Recommended FFC Connector:
  - TFT: 40 pin 0.5mm pitch; Ex. Molex 54132-4062
  - RTP: 4pin 1.0mm pitch
6. EMI Shielded FPC

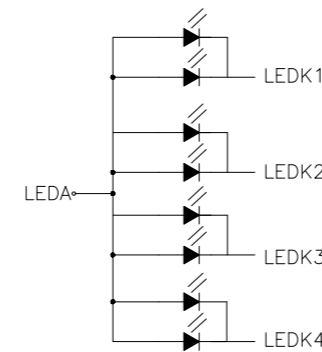

LED CIRCUIT DIAGRAM

<b>Standard Tolerance:</b> (Unless otherwise specified)  Linear: ±0.3mm		
	Drawing/Part Number: <b>NHD-2.4-240320AF-CSXP-T</b>	Revision: <b>2A</b>
<b>Unless otherwise specified:</b> • Dimensions are in Millimeters • Third Angle Projection	Drawn By: K. Lewis	Approved By: K. Lewis
	Drawn Date: 08/22/2023	Approved Date: 08/22/2023
This drawing is solely the property of Newhaven Display International, Inc. The information it contains is not to be disclosed, reproduced or copied in whole or part without written approval from Newhaven Display.		

## Pin Description

Pin No.	Symbol	External Connection	Function Description
1	GND	Power Supply	Ground
2	YD	Touch Controller	Touch Panel - Down
3	XL	Touch Controller	Touch Panel - Left
4	YU	Touch Controller	Touch Panel - Up
5	XR	Touch Controller	Touch Panel - Right
6	SDO	MPU	Serial Data Out
7	VDD	Power Supply	Supply Voltage for LCD (3.3V)
8	VDDI	Power Supply	Supply Voltage for Logic
9	SDA	MPU	Serial Data In
10	CSX	MPU	Active LOW Chip Select signal
11	DCX	MPU	Data / Command selection: '1' = Data; '0' = Command
12	WRX	MPU	Active LOW Write signal
13	RDX	MPU	Active LOW Read signal
14	DB0	MPU	Bi-directional data bus  8-bit: use DB8-DB15 16-bit: use DB0-DB15
15	DB1	MPU	
16	DB2	MPU	
17	DB3	MPU	
18	DB4	MPU	
19	DB5	MPU	
20	DB6	MPU	
21	DB7	MPU	
22	DB8	MPU	
23	DB9	MPU	
24	DB10	MPU	
25	DB11	MPU	
26	DB12	MPU	
27	DB13	MPU	
28	DB14	MPU	
29	DB15	MPU	
30	RESX	MPU	Active LOW Reset signal
31	IM0	MPU	Interface Mode Select
32	IM2	MPU	Interface Mode Select
33	GND	Power Supply	Ground
34	LED-K1	Power Supply	Backlight Cathode (Ground)
35	LED-K2	Power Supply	
36	LED-K3	Power Supply	
37	LED-K4	Power Supply	
38	LED-A	Power Supply	Backlight Anode (3.0V/160mA)
39	GND	Power Supply	Ground
40	TE	MPU	Tearing effect output

**Recommended LCD connector:** 40-pin, 0.5mm pitch FFC connector

**Molex P/N:** 54132-4062 or similar

## Interface Selection

Pin Name	8-bit 8080-II Parallel	16-bit 8080-II Parallel	3-wire SPI
IM0	1	0	1
IM2	0	0	1



## Wiring Diagram

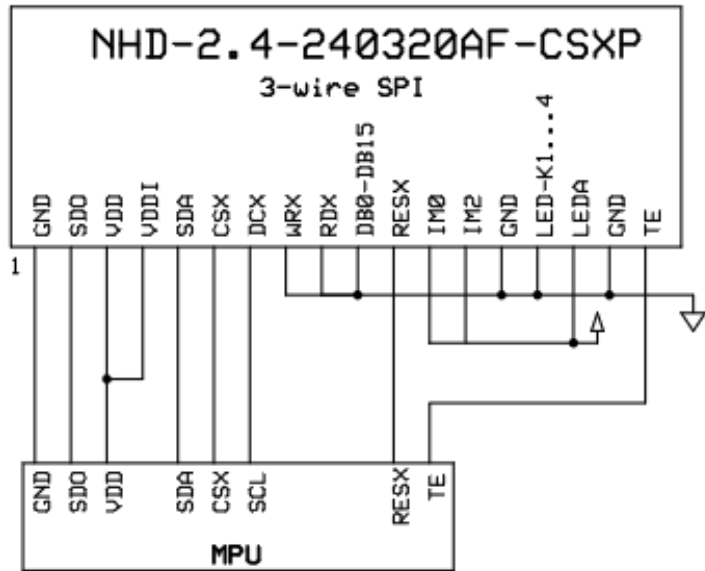
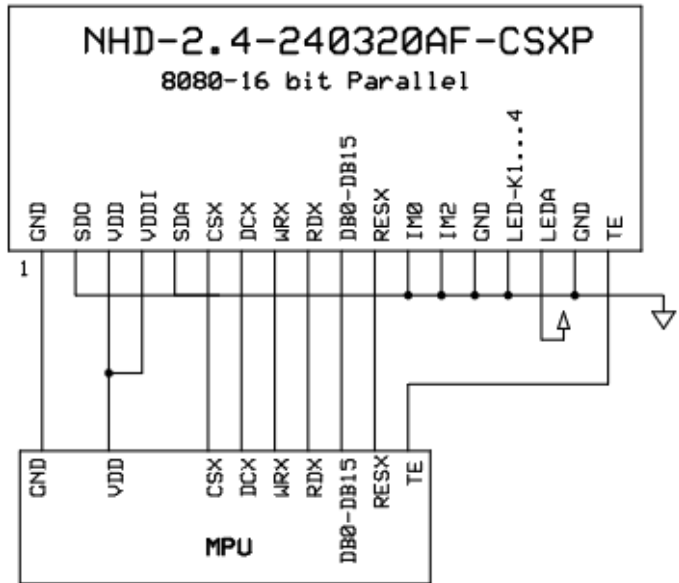
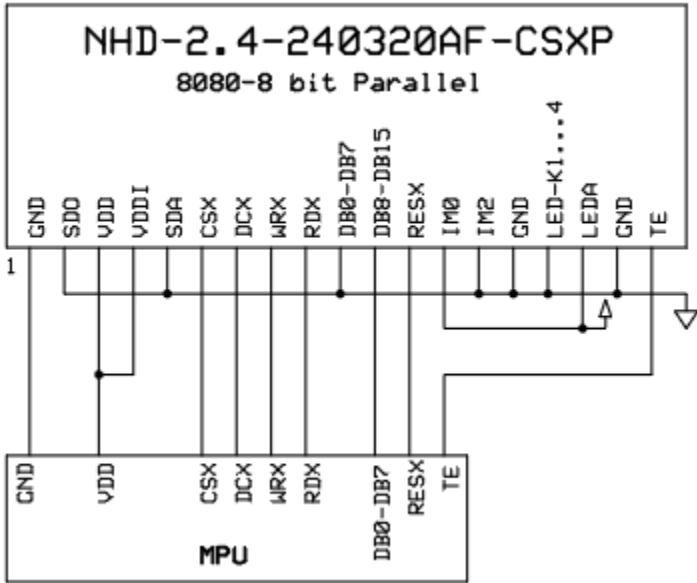

## Electrical Characteristics

Item	Symbol	Condition	Min.	Typ.	Max.	Unit
Operating Temperature Range	T <sub>OP</sub>	Absolute Max	-20	-	+70	°C
Storage Temperature Range	T <sub>ST</sub>	Absolute Max	-30	-	+80	°C
Supply Voltage for LCD	V <sub>DD</sub>	-	2.4	3.3	3.6	V
Supply Voltage for Logic	V <sub>DDI</sub>	-	1.65	1.8	3.6	V
Supply Current	I <sub>DD</sub>	V <sub>DD</sub> = 3.3V	5	10	15	mA
"H" Level input	V <sub>IH</sub>	-	0.7 * V <sub>DDI</sub>	-	V <sub>DDI</sub>	V
"L" Level input	V <sub>IL</sub>	-	GND	-	0.3 * V <sub>DDI</sub>	V
"H" Level output	V <sub>OH</sub>	-	0.8 * V <sub>DDI</sub>	-	V <sub>DDI</sub>	V
"L" Level output	V <sub>OL</sub>	-	GND	-	0.2 * V <sub>DDI</sub>	V
Backlight Supply Current	I <sub>LED</sub>	-	80	160	200	mA
Backlight Supply Voltage	V <sub>LED</sub>	I <sub>LED</sub> = 160mA	2.7	3.0	3.4	V
Backlight Lifetime*	-	I <sub>LED</sub> = 160mA T <sub>OP</sub> = 25°C	30,000	50,000	-	Hrs.

\*Backlight Lifetime is rated as Hours until **half-brightness**, under normal operating conditions. The LED of the backlight is driven by current drain; drive voltage is for reference only. Drive voltage must be selected to ensure backlight current drain is below MAX level stated.

## Optical Characteristics

Item		Symbol	Condition	Min.	Typ.	Max.	Unit
Optimal Viewing Angles	Top	φY+	CR ≥ 10	70	80	-	°
	Bottom	φY-		70	80	-	°
	Left	θX-		70	80	-	°
	Right	θX-		70	80	-	°
Contrast Ratio		CR	-	1000	1500	-	-
Luminance		L <sub>V</sub>	I <sub>LED</sub> = 160mA	800	960	-	cd/m <sup>2</sup>
Response Time		T <sub>R</sub> + T <sub>F</sub>	T <sub>OP</sub> = 25°C	-	35	45	ms
Chromaticity	Red	X <sub>R</sub>	-	0.585	0.635	0.685	-
		Y <sub>R</sub>	-	0.291	0.341	0.391	-
	Green	X <sub>G</sub>	-	0.276	0.326	0.376	-
		Y <sub>G</sub>	-	0.569	0.619	0.669	-
	Blue	X <sub>B</sub>	-	0.105	0.155	0.205	-
		Y <sub>B</sub>	-	0.026	0.076	0.126	-
	White	X <sub>W</sub>	-	0.283	0.313	0.343	-
		Y <sub>W</sub>	-	0.299	0.329	0.359	-

## Touch Panel Characteristic

Item	Min.	Typ.	Max.	Unit
Linearity	-	-	1.5	%
Circuit Resistance – X-Axis	200	-	600	$\Omega$
Circuit Resistance – Y-Axis	250	-	900	$\Omega$
Insulation Resistance	20	-	-	M $\Omega$
Operating Voltage	-	-	5	V
Chattering	-	-	15	ms
Activation Force	100	-	-	gf
Pen Writing Durability	100,000	-	-	Characters
Pitting Durability	1,000,000	-	-	Touches
Surface Hardness	3	-	-	H

## Controller Information

Built-in ST7789VI Controller: <https://support.newhavendisplay.com/hc/en-us/articles/10814990300823-ST7789VI>



# Timing Characteristics for TFT

## Parallel 8/16-bit Interface Timing Characteristics

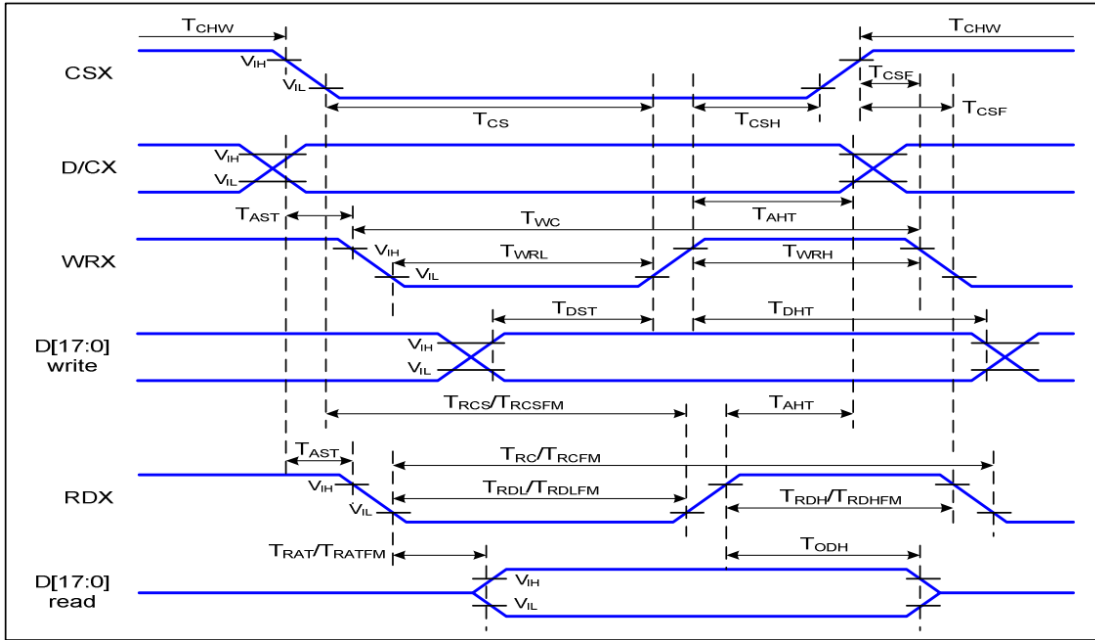

Signal	Symbol	Parameter	Min	Max	Unit	Description
D/CX	$T_{AST}$	Address setup time	0		ns	-
	$T_{AHT}$	Address hold time (Write/Read)	10		ns	
CSX	$T_{CHW}$	Chip select "H" pulse width	0		ns	-
	$T_{CS}$	Chip select setup time (Write)	15		ns	
	$T_{RCS}$	Chip select setup time (Read ID)	45		ns	
	$T_{RCSFM}$	Chip select setup time (Read FM)	355		ns	
	$T_{CSF}$	Chip select wait time (Write/Read)	10		ns	
	$T_{CSH}$	Chip select hold time	10		ns	
WRX	$T_{WC}$	Write cycle	66		ns	-
	$T_{WRH}$	Control pulse "H" duration	15		ns	
	$T_{WRL}$	Control pulse "L" duration	15		ns	
RDX (ID)	$T_{RC}$	Read cycle (ID)	160		ns	When read ID data
	$T_{RDH}$	Control pulse "H" duration (ID)	90		ns	
	$T_{RDL}$	Control pulse "L" duration (ID)	45		ns	
RDX (FM)	$T_{RCFM}$	Read cycle (FM)	450		ns	When read from frame memory
	$T_{RDHFM}$	Control pulse "H" duration (FM)	90		ns	
	$T_{RDLFM}$	Control pulse "L" duration (FM)	355		ns	
D[17:0]	$T_{DST}$	Data setup time	10		ns	For CL=30pF
	$T_{DHT}$	Data hold time	10		ns	
	$T_{RAT}$	Read access time (ID)		40	ns	
	$T_{RATFM}$	Read access time (FM)		340	ns	
	$T_{ODH}$	Output disable time	20	80	ns	

### 3-line Serial interface Timing Characteristics

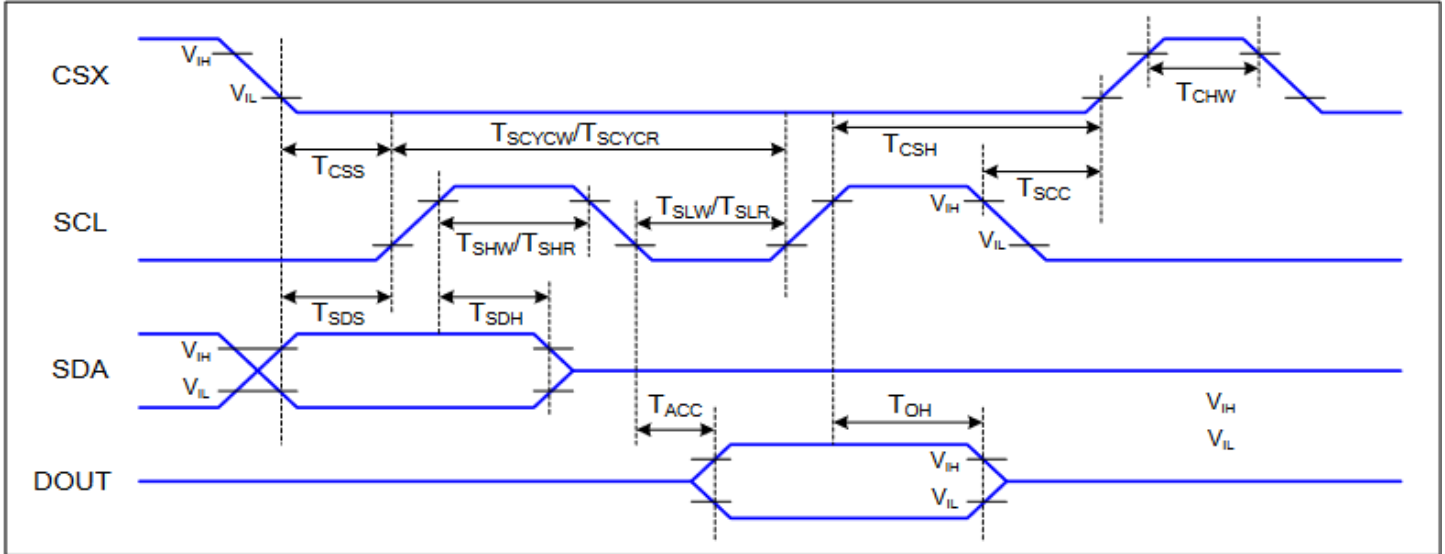

Signal	Symbol	Parameter	Min	Max	Unit	Description
CSX	$T_{CSS}$	Chip select setup time (write)	15		ns	
	$T_{CSH}$	Chip select hold time (write)	15		ns	
	$T_{CSS}$	Chip select setup time (read)	60		ns	
	$T_{SCC}$	Chip select hold time (read)	65		ns	
	$T_{CHW}$	Chip select "H" pulse width	40		ns	
SCL	$T_{SCYCW}$	Serial clock cycle (Write)	16		ns	
	$T_{SHW}$	SCL "H" pulse width (Write)	7		ns	
	$T_{SLW}$	SCL "L" pulse width (Write)	7		ns	
	$T_{SCYCR}$	Serial clock cycle (Read)	150		ns	
	$T_{SHR}$	SCL "H" pulse width (Read)	60		ns	
	$T_{SLR}$	SCL "L" pulse width (Read)	60		ns	
SDA (DIN)	$T_{SDS}$	Data setup time	7		ns	
	$T_{SDH}$	Data hold time	7		ns	
DOUT	$T_{ACC}$	Access time	10	50	ns	For maximum CL=30pF
	$T_{OH}$	Output disable time	15	50	ns	For minimum CL=8pF

## Reset Timing

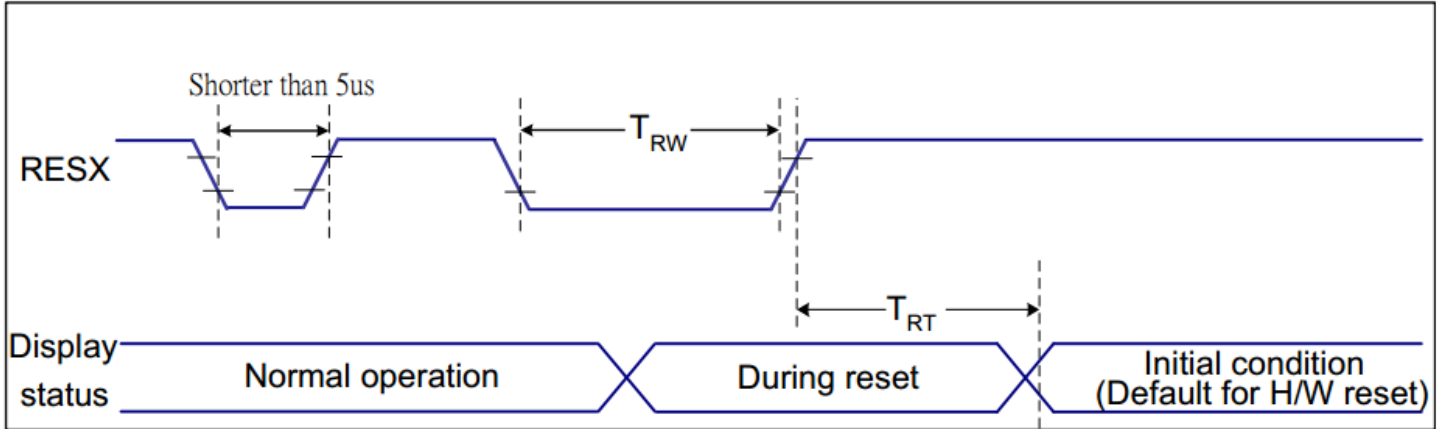

Related Pins	Symbol	Parameter	MIN	MAX	Unit
RESX	TRW	Reset pulse duration	10	-	us
	TRT	Reset cancel	-	5 (Note 1, 5)	ms
				120 (Note 1, 6, 7)	ms

## Power ON/OFF Sequence

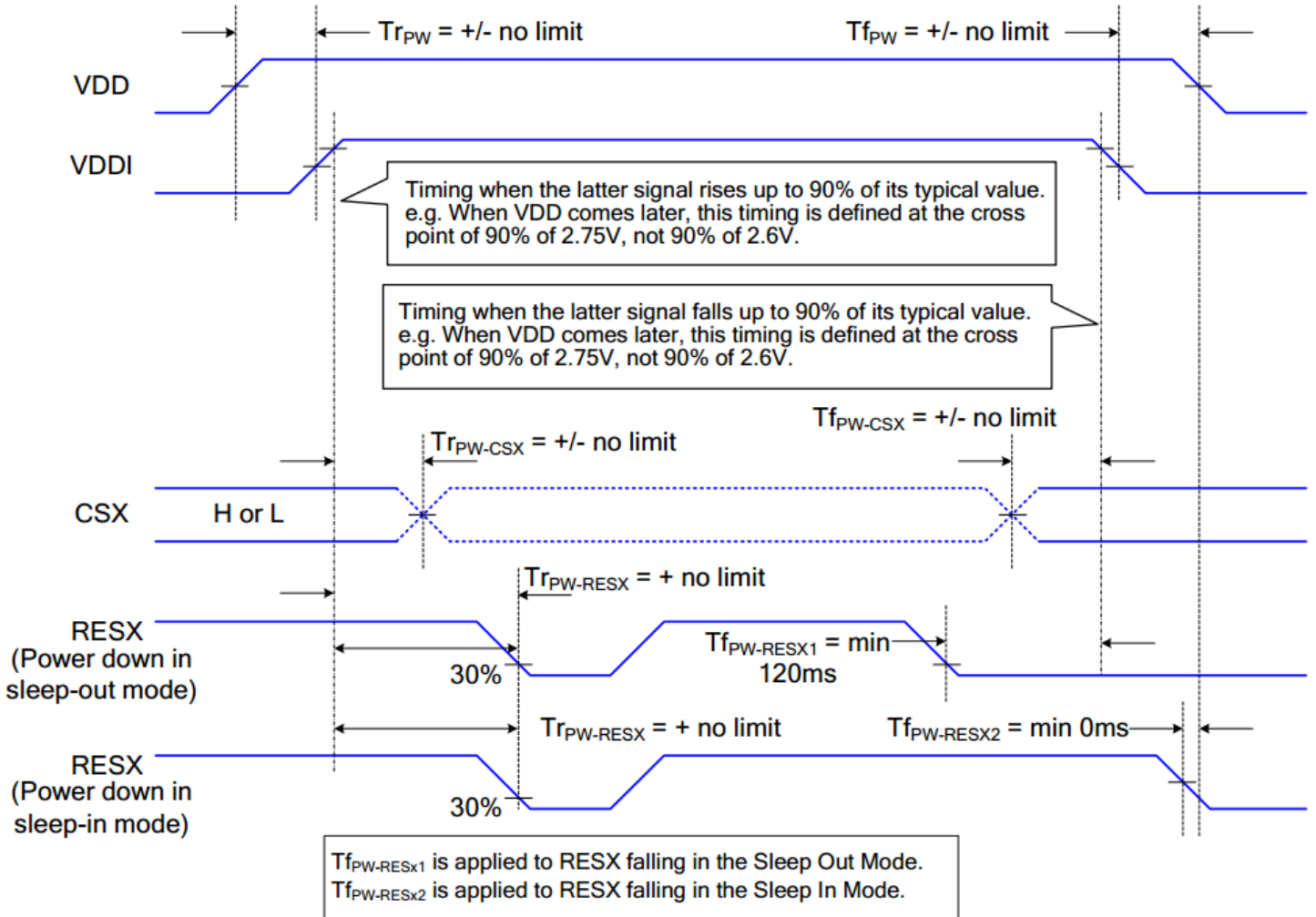

## Example Initialization Code

**TBD**

## Quality Information

Test Item	Content of Test	Test Condition	Note
High Temperature Storage	Endurance test applying the high storage temperature for a long time.	+80°C, 240hrs	2
Low Temperature Storage	Endurance test applying the low storage temperature for a long time.	-30°C, 240hrs	1,2
High Temperature Operation	Endurance test applying the electric stress (voltage & current) and the high thermal stress for a long time.	+70°C, 240hrs	2
Low Temperature Operation	Endurance test applying the electric stress (voltage & current) and the low thermal stress for a long time.	-20°C, 240hrs	1,2
High Temperature / Humidity Operation	Endurance test applying the electric stress (voltage & current) and the high thermal with high humidity stress for a long time.	+60°C, 90% RH, 240hrs	1,2
Thermal Shock resistance	Endurance test applying the electric stress (voltage & current) during a cycle of low and high thermal stress.	-30°C 30min -> 25°C 3min -> 80°C 30min = 1 cycle. For 100 cycles	
Vibration test	Endurance test applying vibration to simulate transportation and use.	10Hz-55Hz, 1.5mm amplitude. 2hrs in each of 3 directions X,Y,Z	3
Static electricity test	Endurance test applying electric static discharge.	Air discharge: ±8kV 10 Times Contact discharge: ±4kV 10 Times	

**Note 1:** No condensation to be observed.

**Note 2:** Conducted after 4 hours of storage at 25°C, 0%RH.

**Note 3:** Test performed on product itself, not inside a container.